



Applied Air®

INSTALLATION, OPERATION AND MAINTENANCE MANUAL FOR INDIRECT GAS-FIRED HEATERS INCLUDING UNITS WITH DDC CONTROLS

ATTENTION: READ THIS MANUAL AND ALL LABELS ATTACHED TO THE UNIT CAREFULLY BEFORE ATTEMPTING TO INSTALL, OPERATE OR SERVICE THESE UNITS! CHECK UNIT DATA PLATE FOR TYPE OF GAS AND ELECTRICAL SPECIFICATIONS AND MAKE CERTAIN THAT THESE AGREE WITH THOSE AT POINT OF INSTALLATION. RECORD THE UNIT MODEL AND SERIAL No.(s) IN THE SPACE PROVIDED. RETAIN FOR FUTURE REFERENCE.

FOR YOUR SAFETY

The use and storage of gasoline or other flammable vapors and liquids in open containers in the vicinity of this appliance is hazardous.

POUR VOTRE SÉCURITÉ

L'utilisation et l'entreposage d'essence ou d'autres liquides ou produits émettant des vapeurs inflammables dans des récipients ouverts à proximité de cet appareil est dangereux.



FOR YOUR SAFETY

If you smell gas:

1. Open Windows
2. Don't touch electrical switches.
3. Extinguish any open flame.
4. Immediately call your gas supplier.



POUR VOTRE SÉCURITÉ

Si vous sentez une odeur de gaz :

1. Ouvrez les fenêtres.
2. Ne pas actionner d'interrupteur.
3. Éteindre toute flamme ouverte.
4. Appelez immédiatement votre fournisseur de gaz.

WARNING: Improper installation, adjustment, alteration, service or maintenance can cause property damage, injury or death. Read the installation, operating and maintenance instructions thoroughly before installing or servicing this equipment.

AVERTISSEMENT : Une installation déficiente, de même qu'un mauvais réglage, modification, entretien ou maintenance peuvent occasionner des dommages matériels, corporels voire causer la mort. Lire attentivement les instructions d'installation, d'utilisation et d'entretien avant d'installer ou d'intervenir sur cet appareil.

WARNING

Install, operate and maintain unit in accordance with manufacturer's instructions to avoid exposure to fuel substances or substances from incomplete combustion which can cause death or serious illness. The state of California has determined that these substances may cause cancer, birth defects, or other reproductive harm.

INSTALLER'S RESPONSIBILITY

Installer Please Note: This equipment has been test fired and inspected. It has been shipped free from defects from our factory. However, during shipment and installation, problems such as loose wires, leaks or loose fasteners may occur. **It is the installer's responsibility to inspect and correct any problems that may be found.**



SECTION I - FOREWORD

As is the case with any fine piece of equipment, care must be taken to provide the proper attention to the operation and maintenance detail of this machine.

This manual of instructions along with Digital Control System User Manual (for systems with optional DDC controls) has been prepared in order for you to become well-acquainted with those details, and in doing so, you will be able to give your Indirect Gas-Fired System the care and attention which any piece of equipment needs and deserves.

It is the customer and installation personnel responsibility to determine if the unit is equipped with all of the safety devices required for the particular application. Safety considerations include the accessibility of the unit to non-service personnel, the provision of electrical lockout switches, maintenance procedures and automatic control sequences. Clearly mark any shutoff devices.

Table of Contents	
Section I: Foreword and Table of Contents	2
Section II: General Information	3
Section III: Installation	4
Section IV: Pre-Start Up	19
Section V: Unit Start Up without DDC Controls	21
Section V: Unit Start Up with DDC Controls	26
Section VI: Unit Shut Down	30
Section VII: Troubleshooting	31
Section VIII: Servicing the Burner	52
Section IX: Maintenance Schedule and Lubrication Requirements	57
Section X: Thermistor Output Curve for units with DDC Controls	62
Section XI: Replacement Parts	63

* IMPORTANT NOTICE *

Applied Air assumes no responsibility for loss or damage in transit; therefore, you should protect yourself by following these instructions. Failure to do so is your responsibility.

BILL OF LADING

Save your bill of lading. It is a contract, and you will need it, provided you have to file a loss or damage claim. Remember, claims are outlawed after nine months.

LOSS IN TRANSIT

Before you sign for this shipment, check against the bill of lading, also the transportation company's delivery ticket. Make sure that you get the exact total of articles listed. Should the delivery ticket show more or less items than you are offered, then the carrier's agent must mark the difference on your freight bill before you sign.

VISIBLE DAMAGE IN TRANSIT

If something is damaged, accept the shipment only if the carrier's agent places a notation on your freight bill explaining the nature and extent of damage. Upon inspection of article, make claim to the delivering carrier.

CONCEALED DAMAGE IN TRANSIT

Sometimes transit damage is not noticed until the goods are unpacked. In such cases, notification to the carrier must be made within fifteen (15) days of receipt of shipment. In such cases, save the packages and packing material, then notify the transportation company at once, and request an inspection. When the inspector calls, have him make out and leave a "concealed" bad order report. He is obliged to give one to you. Insist on it.

DISPOSITION OF DAMAGED ARTICLES

Never return damaged articles to us. They are the property of the transportation company when the claim is filled. They will give you disposition instructions.

PACKING

We comply with the packing requirements of the transportation companies, and your bill of lading proved that everything was in good condition when shipped. That bill of lading contract requires them to deliver in perfect condition.

SECTION II - GENERAL INFORMATION

A. Purpose

The purpose of this manual is to present a guide for proper installation, maintenance, and operation of the Indirect Gas-Fired System, and supplement, **but not to replace**, the services of qualified field service personnel to supervise the initial start-up and adjustment of the unit. Persons without previous experience with large commercial and industrial heating equipment should not attempt the initial adjustment and checkout procedure, which is essential before such installations may be considered ready for operation. This manual should be made readily available to all operating personnel as an aid in troubleshooting and proper maintenance. Due to the custom nature of Applied Air equipment, not all possibilities are addressed in this manual. The customer or installer can obtain information from Applied Air's sales representative or the Applied Air factory.

WARNING: Failure to comply with general safety information may result in extensive property damage, severe personal injury or death.

B. Shipping

Base Indirect Gas-Fired units are shipped completely assembled where shipping limitations allow. Optional inlet hoods, filter and /or damper sections, or other large accessories are assembled and shipped mounted and wired whenever possible within limitations of shipping and handling. Some optional accessories shipped separately may require field assembly. Any wired accessories, which have been disassembled for separate shipment, require no additional conduit or wire for field reassembly. All wire leads will be tagged for ease of reconnection in the field.

If the heater and/or accessories cannot be installed immediately, they should be stored in a clean dry environment. If this is not possible and the heater must be stored outdoors, it should be protected from the weather with tarpaulins or plastic coverings. Rotate the fans monthly. Prior to beginning installation of a unit that has been in storage for weeks or months, the unit and its components should be closely inspected.

Prior to beginning installation of a unit that has been in storage for weeks or months, the unit and its components should be closely inspected.

Shipments are made F.O.B. Dallas, Texas by truck. The unit is securely strapped, tied, and blocked to prevent shipping damage. All shipments are checked by an inspector before they are accepted by the carrier. Parts that are shipped un-mounted are noted on the bill of lading. These parts, where feasible, are packaged and shipped with the units. Upon receipt of shipment, all units should be checked against the bill of lading to insure all items have been received. All equipment (and any optional accessories) should be checked carefully for physical damage in the presence of the carrier's representative. If parts are missing or damage has occurred, a claim should be filed immediately with the carrier.

All Indirect Gas-Fired units are given a complete operations test and control circuit checkout before shipment. Copies of the wiring diagram, piping diagram and bill of material are included with each unit shipped. If correspondence with the factory is necessary, please provide the unit model and serial number.

C. Optional Factory Service

Periodic service on any piece of mechanical equipment is necessary for efficient operation. A nationwide service support network is available to provide quick and dependable servicing of make-up air, heating, ventilating, or air handling types of equipment. The factory also offers start-up service, which includes the presence of a service engineer to supervise the initial start-up and adjustment of the equipment and provide instructions for the owner's maintenance personnel in proper operations and maintenance. Consult factory for quotations on periodic or start-up service.

SECTION III - INSTALLATION

FOR CANADIAN INSTALLATIONS ONLY

1. All installations must conform with local building codes, or in the absence of local codes, with current CAN/CGA-B149-Installation Codes for Gas Burning Appliances and Equipment.
2. All electrical connections must be in accordance with Canadian Electrical Code, Part 1, CSA Standard C22.1.

All electrical connections must conform to the current edition of ANSI/NFPA No. 70 National Electrical Code and applicable local codes: in Canada, to the Canadian Electrical Code, Part 1 CSA Standard C22.1. The following recommendations are not intended to supplant any requirement of federal, state, or local codes having jurisdiction. Authorities having jurisdiction should be consulted before installations are made. Local codes may require additional safety controls and /or interlocks. All installations in airplane hangers must be in accordance with current ANSI/NFPA No. 409. All installations in public garages must be in accordance with current NFPA No. 88A and NFPA No. 88B.

CAUTION: Do not install heating system in corrosive or flammable atmospheres! Premature failure of, or severe damage to the unit will result!

CAUTION: Heating system must not be installed in locations where air for combustion would contain chlorinated, halogenated or acidic vapors. If located in such an environment, premature failure of the unit will occur!

A. Handling the Equipment

As explained previously, the basic unit is designed for shipping in one piece where shipping limitations allow. Some optional accessories may require field mounting.

The Indirect Gas-Fired unit has been designed for rigging and handling through the use of special lifting lugs installed on the top and/or sides of each unit. When unloading and setting the unit, use the lifting lugs provided as shown in Drawing #C000539 or move the equipment on rollers. Hooks, jacks, or chains must not be used around the casing, main control panel or exterior mounted controls.

During transit, unloading and setting of the unit; bolts and nuts may have become loosened, particularly in the pillow block ball bearing assemblies in the fan section. It is recommended that all nuts and set screws be tightened. Turn fan shaft by hand to make certain that blower does not rub against blower housing, and that bearing set screws are tight.

If units are not set immediately, cover all openings that might be exposed to the weather.

Rotate fans monthly.

IMPORTANT: Lift and install the modules or sections of a unit separately. Flange connections provided between modules or sections are not structural and damage will occur if any attempt is made to lift modules that have flanged together.

See the specification sheet and submittal drawing for unit or section weight and to determine proper orientation for each section.

When unloading sections and/or units or moving equipment to its final location, exercise care to avoid distortion. Lift sections and/or units only by the lifting lugs provided and follow the procedures as outlined below.

RIGGING AND MOUNTING – INDIRECT FIRED UNITS

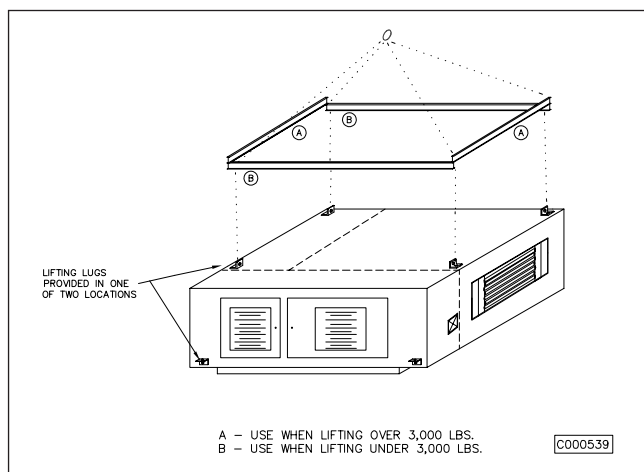

Warning: To insure that a proper unit lift is made, lift unit approximately 24 inches and verify proper center of gravity lift point. To avoid dropping of unit, reposition lifting point if unit is not level. Failure to properly lift unit could result in death or serious injury or possible equipment or property-only damage.

B. Locating the Unit

Prior to locating the unit, authorities having jurisdiction should be consulted before installations are made. Approval permits should be checked against the unit received.

Combustion air shall be provided at a rate of at least 0.20 CFM, or 1 square inch of free opening, per 1000 BTU per hour of rated input. If a separate mechanical means provides this air, an interlock with the combustion blower shall be provided.

The rated output of gas burning appliances decreases with higher altitudes above 2,000 feet, the furnace shall be de-rated 4 % for each additional 1,000 feet of altitude above sea level. Factory testing rating plate information is recorded on sea level conditions. High altitude ratings may be obtained by a change in manifold pressure. Appliances must be suitably marked to indicate their altitude adjusted input rating.

Under no circumstances should this equipment be installed in a negatively pressurized space. Consult jurisdictional authority for proper ventilation requirements.

Combustion air containing or recirculation of room air may be hazardous in the presence of:

- a) Flammable solids, liquids and gases.
- b) Explosive materials (i.e., grain, dust, coal dust, gunpowder, etc).
- c) Substances, which may become toxic when, exposed to heat (i.e., refrigerant, aerosols, etc.).

Locate the unit exactly level. Special attention should be given to the duct, electrical, and fuel connection points. Install ductwork with adequate flexible connection to isolate vibration from the ductwork.

All ductwork should have taped or caulked seams. Ductwork should be properly sized so as not to inhibit airflow. This information should be crossed-checked with the position of support beams and stand pipes to insure that clearance dimensions coincide with those of the unit. The minimum clearance to combustible material must be maintained as listed in Table 1

Table 1

Minimum clearance to combustible material, also, consult local codes and regulations.

Clearances to Combustible Material		
	Vertical Units	Horizontal Units
Front*	48 inches	48 inches
Rear	18 inches	18 inches
Right	18 inches	18 inches
Left	18 inches	18 inches
Top	18 inches	18 inches
Floor	Zero	6 inches

*Consider control side as front of unit

In addition to the combustible clearances listed above, access for service should be allowed around the unit. The recommended minimum access clearance is shown in Table 2.

Table 2

Unit Size	Minimum Access*	Unit Size	Minimum Access*
Up to 1750 MBH Output	36 inches	2000 MBH Output and Larger	50 inches

*Optimum clearance for shaft removal would be equivalent to cabinet width.

Make a visual inspection to insure no damage has occurred to the unit during installation.

C. Curb Mounted Units

Outdoor units can be supplied with an optional roof curb. The curb greatly facilitates installation thereby reducing installation costs. All connections to the unit: duct, piping, electrical power and control wiring can be made through the roof opening. The curb may be shipped prior to unit shipment. All curbs are shipped un-assembled from the factory.

Use extreme caution in handling the curb. Proper handling and positioning will assure a water-tight curb unit installation.

Re-check approval prints prior to installation. Be sure that there are no obstructions to ducting and that proper planning has been exercised in connection of piping and/or electrical services.

The curb assembly may be bolted or welded to either trusses or roof decking; however, connection to roof trusses is recommended. The curb is designed to carry the weight of the unit. Additional support is required for certain applications.

Placement of the curb is critical in squareness and leveling. Shims for leveling must be applied to the curb; application of shims to the unit will tend to destroy the sealing effect after installation. Make sure sealing tape is in place before unit is set. Be careful not to allow gaps where two pieces of sealing tape meet. A bubble level must be used in the leveling process. Measure across diagonals to check for squareness. Allowable tolerance is 1/4" difference between diagonal measurements. Double-check approval prints before setting the unit.

Upon completion of setting the curb, apply roofing material and flashing as required.

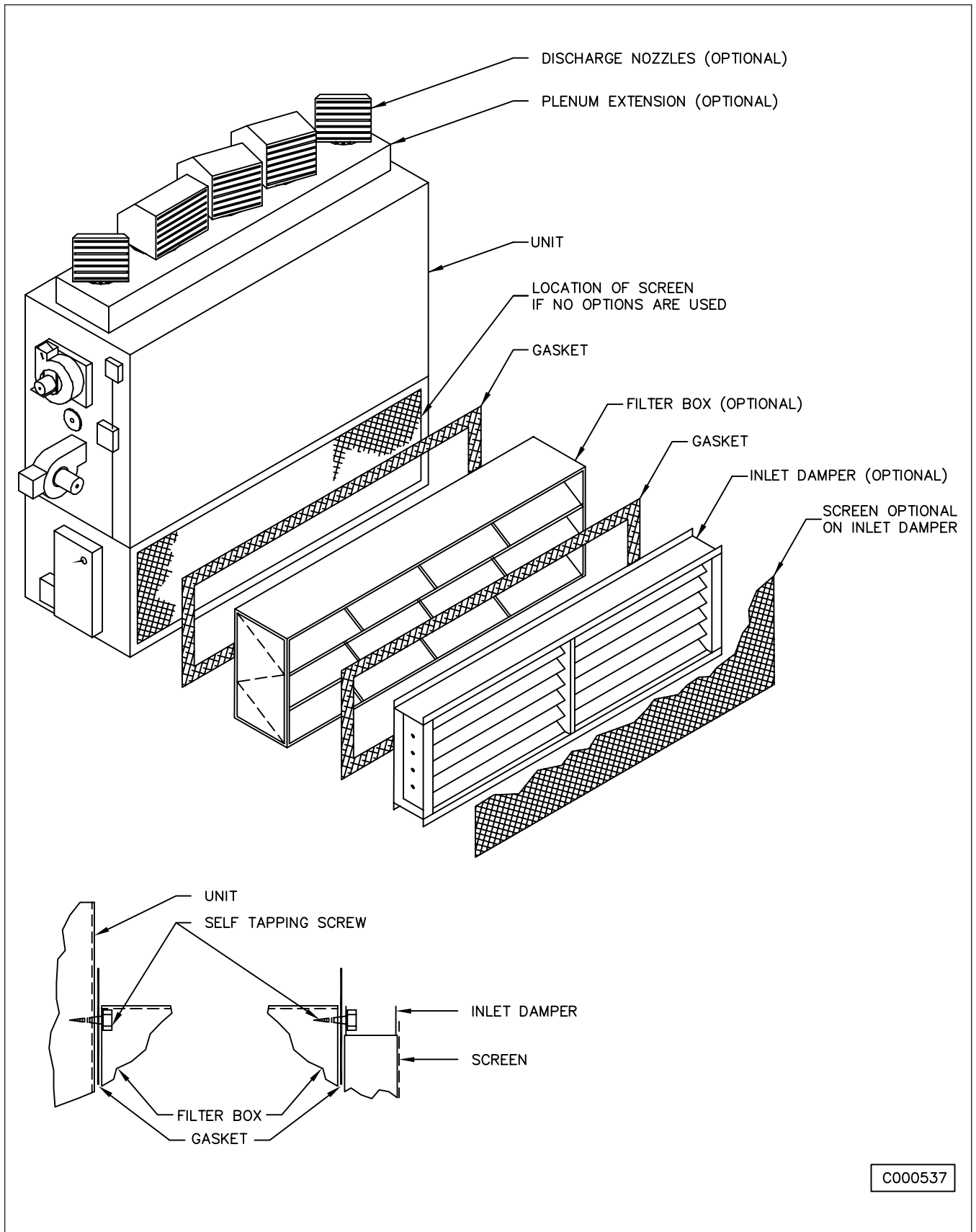

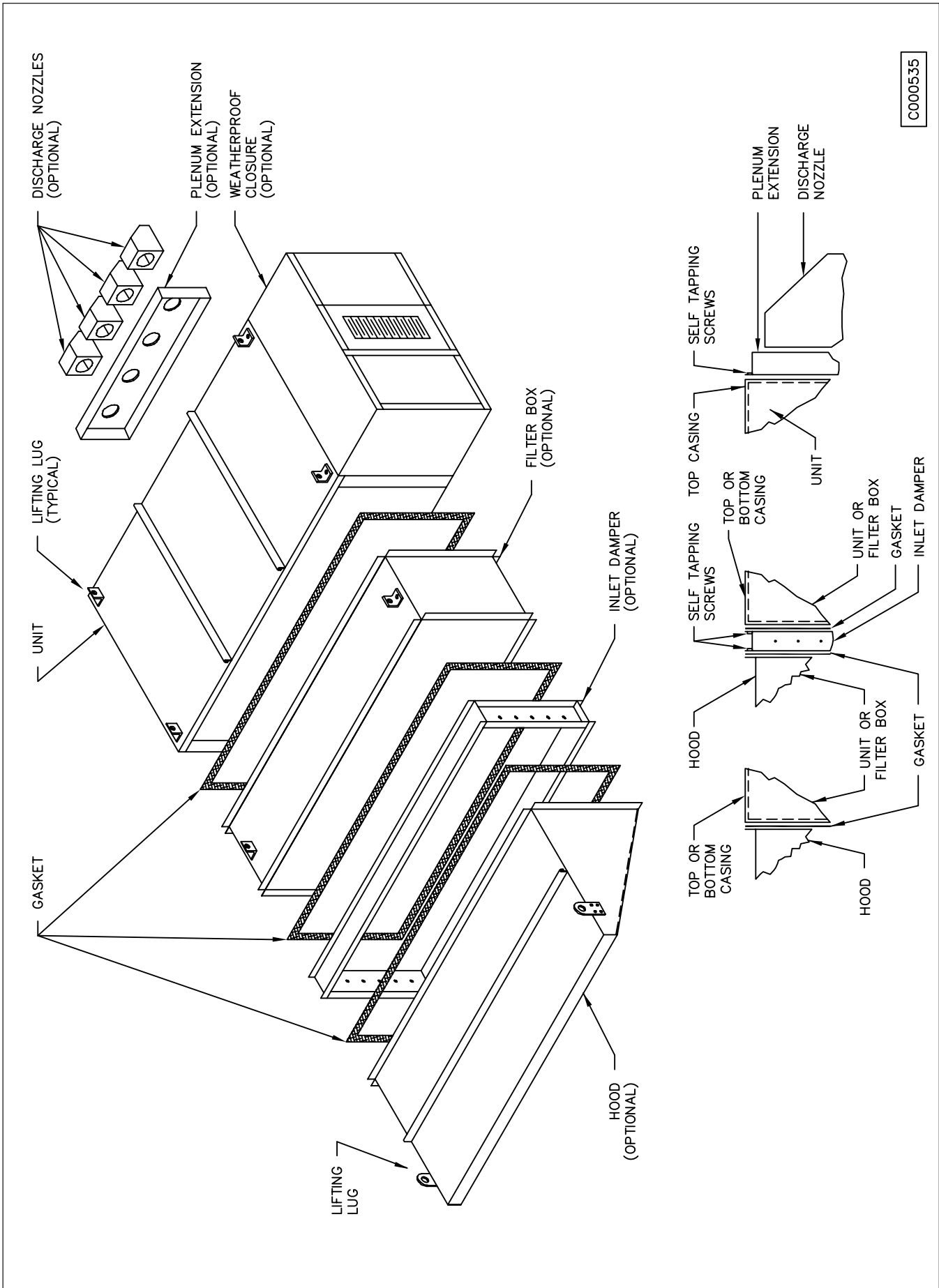

C000535

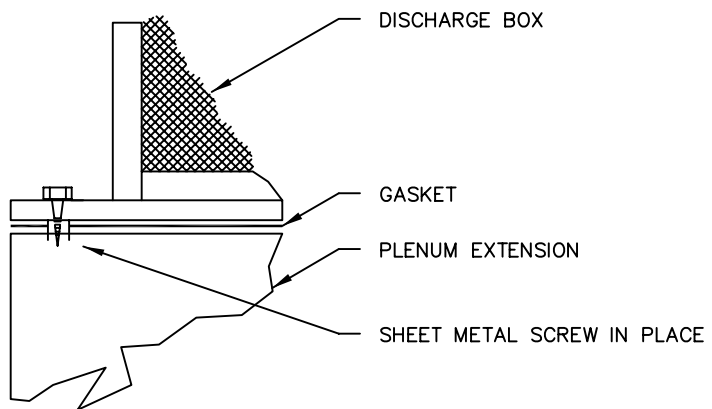
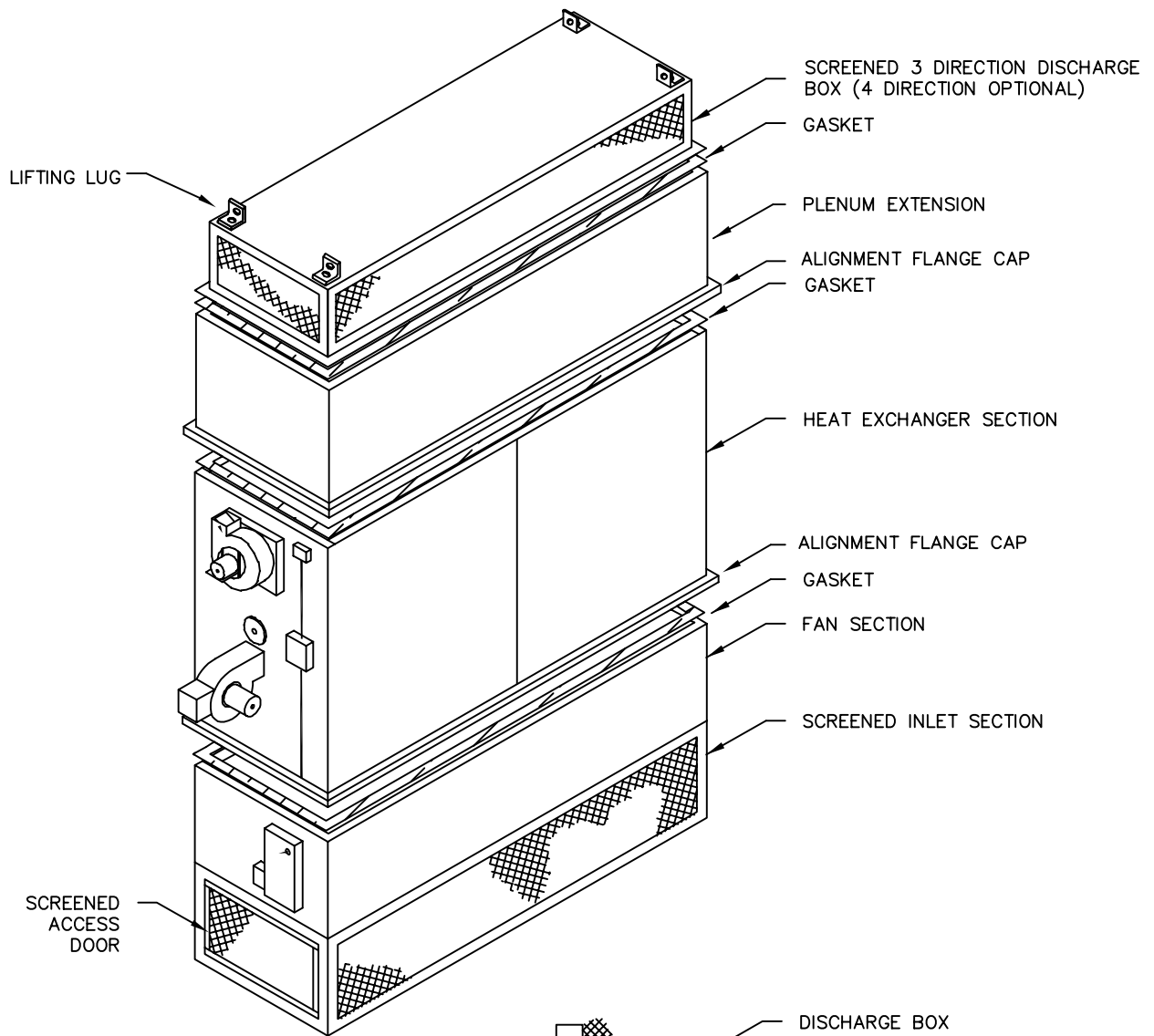

C000536

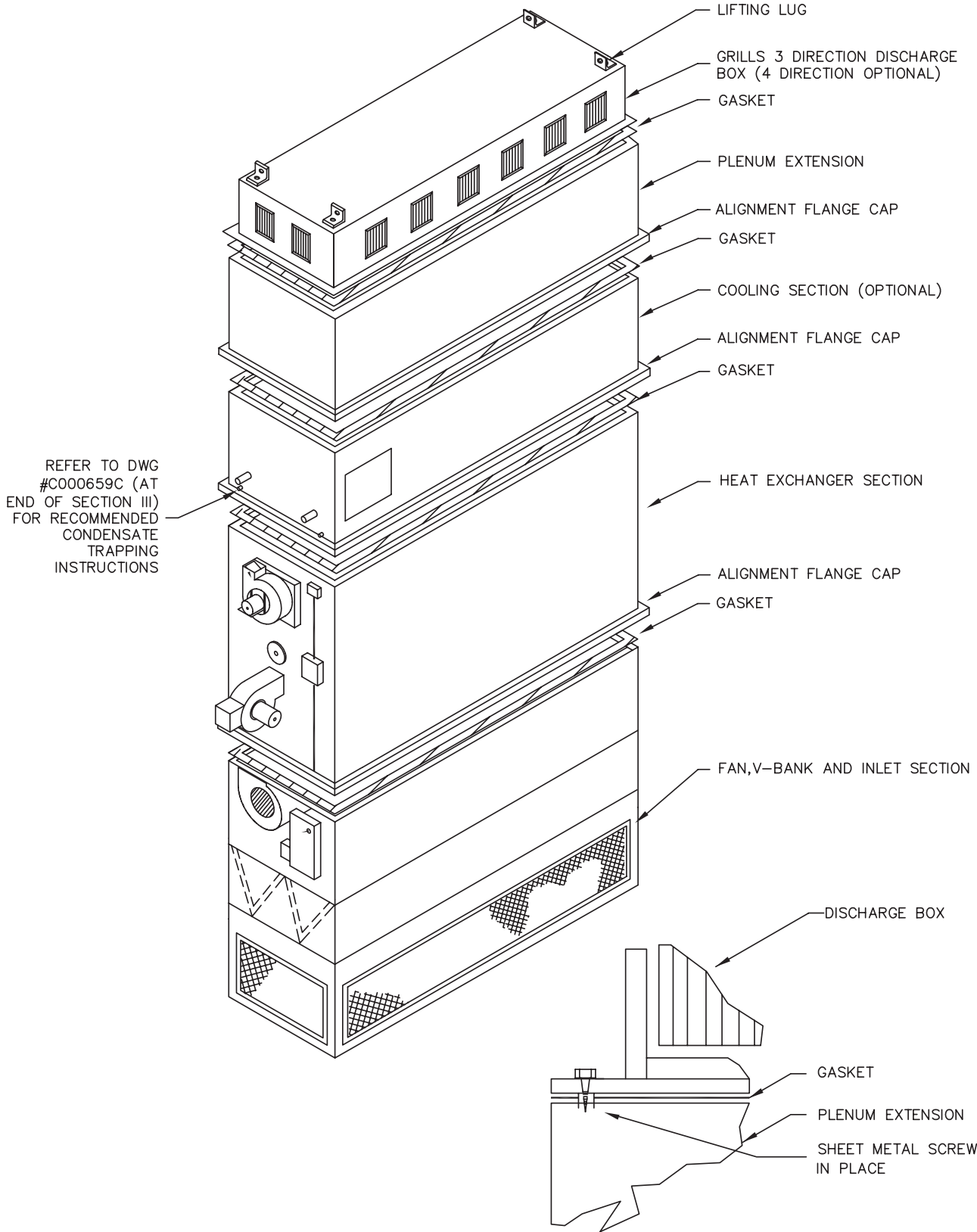

C000538A

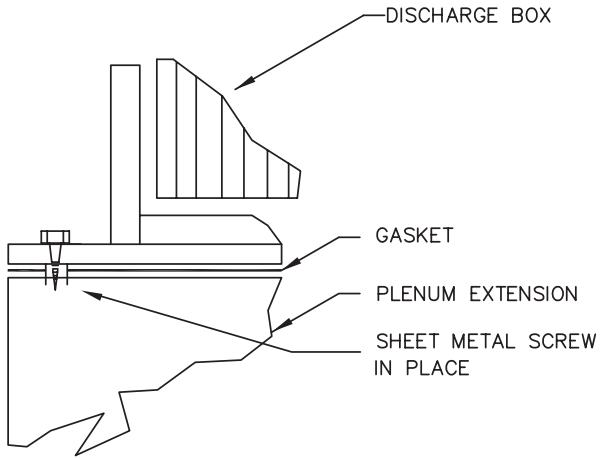
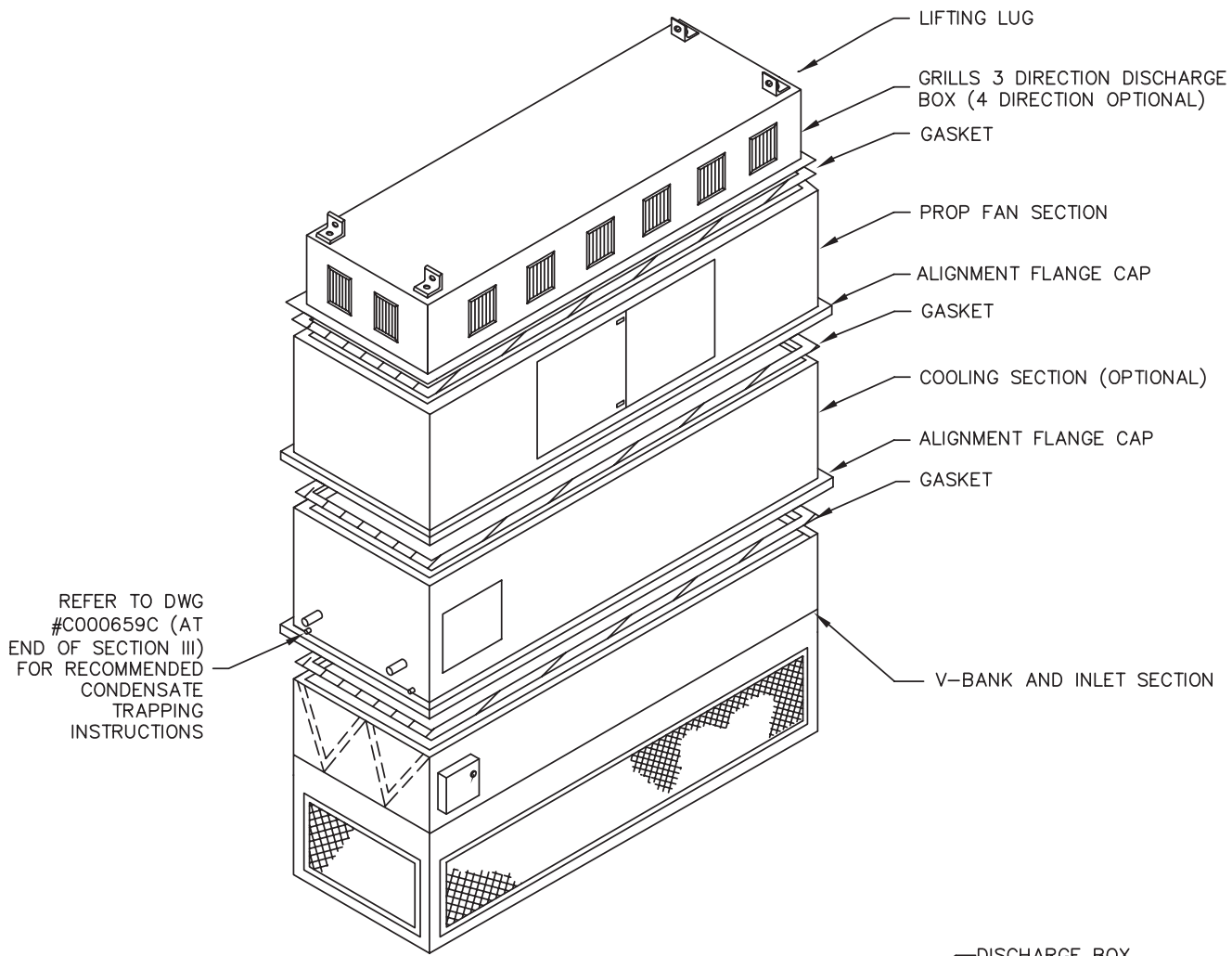

C000712A

DIRECTIONS FOR FIELD ASSEMBLING AND WEATHERPROOFING SECTIONS

1. Apply gasket material to the end of the first section (blower, discharge, heater, ets). (See Fig. 1.)

NOTE: One roof cap is attached to a standing seam on each section for shipping purposes only. It will be necessary to remove this PRIOR TO SLIDING SECTIONS TOGETHER. Failure to do so may damage seams, preventing proper seal.

2. Slide adjoining section against the tacky taped first section. If bolt holes are provided, bolt the sections together tightly. If bolt holes are not provided, use furniture clamps to pull sections TIGHTLY together. Sections, whether bolted or not, will be held together and sealed by the standing seams and hugger strips (Fig. 2), which will be attached later.

3. Once the sections are connected, apply caulking or silicone sealant along the standing roof seam (Fig. 3) and side seams where the sections come together. (Fig.1) It is mandatory to seal the roof and side seams along the entire outside of the unit, and it is strongly suggested that the seams also be sealed along the inside of the unit, if possible.

4. Apply caulking material along the top of both sides of the standing roof seam (Fig.4). Place roof cap (Fig. 4) on top of the seam and secure it with two rows of TEK screws (one down each side), spaced approximately 8-10 inches apart down the entire length of the seam.

5. Apply two strips of tacky tape (one down each side) to the back side of each hugger strip (Fig. 2). Secure hugger strip with two rows of TEK screws (one down each side) spaced approximately 8-10 inches apart down the entire length of the seam.

6. After hugger strips are installed, caulk around the edges to complete the seal.

7. Repeat this process for each section as it is attached. The number of sections varies by application.

NOTE: HOOD REQUIRES ADDITIONAL, INSTALLER PROVIDED, SUPPORT.

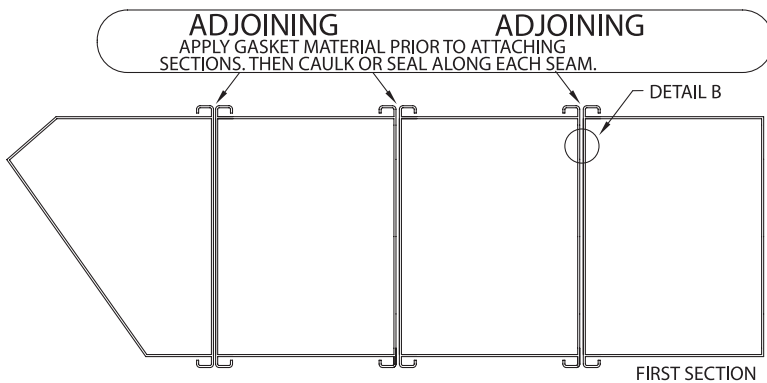

FIGURE 1

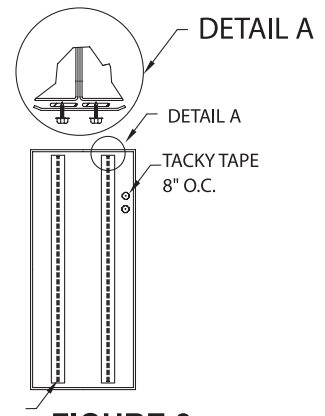

FIGURE 2

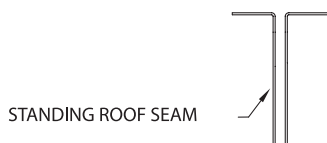

FIGURE 3

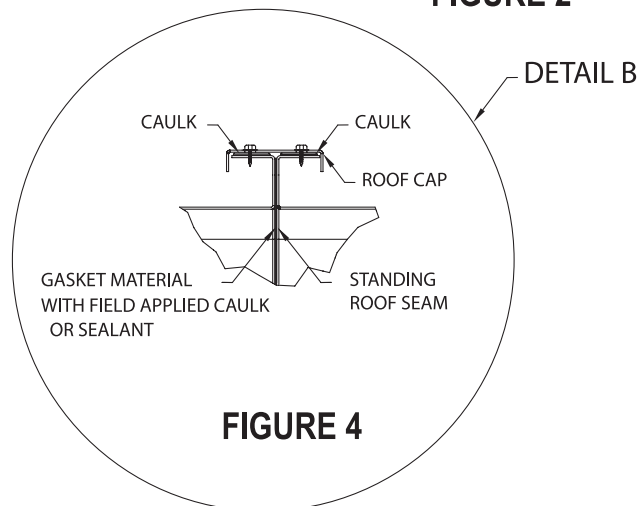

FIGURE 4

D. Location of Accessories

Where applicable, standard or optional accessories will be placed inside the fan section of the unit for shipment, and must be removed and installed by the mechanical or electrical contractor.

Remotely located discharge or inlet dampers must be equipped with an end switch and interlocked to insure maximum design opening before starting and running circuits may be energized.

Field constructed intake accessories should be properly designed to minimize the entry of rain and snow.

Adequate building relief must be provided, so as to not over-pressurize the building, when the heater is operating at its rated capacity. This can be accomplished by taking into account, through standard engineering methods, the structure's designed infiltration rate, by providing properly sized relief openings, by interlocking a powered exhaust system, or by a combination of these methods.

E. Electrical Connections

Warning: Open all disconnect switches and secure in that position before wiring unit. Failure to do so may result in personal injury or death from electrical shock.

Warning: Controls must be protected from water. Do not allow water to drip on the electrical controls.

Note: Before installing any wiring, check the unit rating plate for power supply voltage, and minimum amperage.

All electrical connections must conform to the current edition of: ANSI/NFPA No. 70 National Electrical Code and applicable state and local codes; in Canada, to the Canadian Electrical Code, Part 1 CSA Standard C22.1 and applicable provincial and local codes. Since shipment of unit may require disassembly after factory check and test, reconnection of some electrical devices will be required in the field. Connect electrical wires (supplied in factory furnished conduit) to appropriate terminals. All leads are tagged to facilitate field connections. See wiring diagram provided with equipment. Complete all wiring to any optional accessories as shown on unit bill of material and electrical wiring diagram as required before applying voltage to the unit.

If damper actuators require field wiring, be sure the gasket and cover are securely mounted and assembly is watertight.

Entry location for all field-installed and control wiring is through the control panel.

If optional disconnect is not furnished with heater, the field provided disconnect must be of the proper size and voltage. Refer to unit nameplate for minimum circuit ampacity and voltage. The disconnect must be installed in accordance with Article 430 of the current edition of ANSI/NFPA No. 70 National Electrical Code, and applicable local codes; in Canada, to the Canadian Electrical Code, Part 1, CSA Standard C22.1.

Check the supply voltage before energizing the unit. The maximum voltage variation should not exceed $\pm 10\%$. Phase voltage unbalance must not exceed 2%.

NOTE: Should any original wire supplied with the heater have to be replaced, it must be replaced with wiring material having a temperature rating of at least 105°C.

F. Venting

All venting installations must conform to Part 7, Venting of Equipment in the current version of the National Fuel Gas Code ANSI Z223.1, or applicable provisions of local building codes. The National Fuel Gas Code is subject to change, questions regarding venting requirements should be directed to the local authority having jurisdiction.

All Indirect Fired Units are Category III appliances and must be vented. Each unit must have an individual vent pipe and vent terminal.

Recommended vent pipe is 14 Gauge Series Stainless Steel. **Type "B" vent is not acceptable.** DO NOT support the weight of the stack on the induced draft fan housing of the unit. Insulate single wall vent pipe exposed to cold air or running through unheated areas.

The venting system for these heaters shall terminate at least four feet below, four feet horizontally from, or one foot above any door, window, or gravity air inlet into any building. All vents must be able to maintain a minimum of $-0.20"$ W.C. in high fire.

Through the wall vents for these heaters shall not terminate over public walkways or over an area where condensate or vapor could create a nuisance or hazard or could be detrimental to the operation or regulators, relief valves, or other equipment.

The vent pipe diameter must be as shown in specification chart on following page. An adaptor from induced draft fan housing to vent pipe must be field supplied.

The vent pipe should be fitted with a drip leg with a clean out and a drain plug in the bottom. The vent pipe shall be constructed so that any water that collects in the stack will remain in the stack drip leg and not drain into the induced draft fan housing. Be sure drip leg is made so water will not fall on heater controls when drain plug is removed.

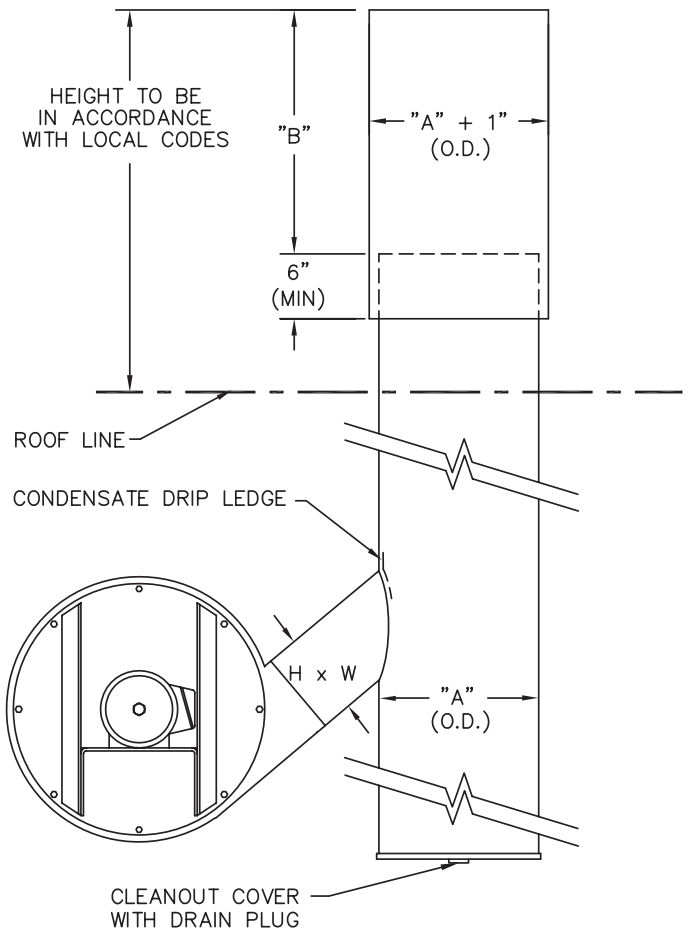

DIMENSIONS				
SIZE	"A"	"B"	"H"	"W"
35	8	32	6-1/4	6-3/8
40	8	32	6-1/4	6-3/8
45	8	32	6-1/4	6-3/8
55	8	32	6-1/4	6-3/8
65	10	40	7	7-3/8
75	10	40	7	7-3/8
85	10	40	7	7-3/8
100	10	40	7	7-3/8
125	12	48	9	9-3/8
150	12	48	9	9-3/8
175	12	48	9	9-3/8
200	14	56	9	9-3/8
250	16	64	10-5/8	11-1/8
275	16	64	10-5/8	11-1/8
300	16	64	10-5/8	11-1/8
325	16	64	10-5/8	11-1/8
350	16	64	10-5/8	11-1/8
400	16	64	10-5/8	11-1/8
500	18	72	10-5/8	11-1/8
600	18	72	10-5/8	11-1/8

- NOTES:
1. WEIGHT OF STACK MUST BE SUPPORTED FROM FLOOR OR BUILDING STRUCTURE. DO NOT SUPPORT STACK FROM INDUCED DRAFT FAN.
 2. RECOMMENDED STACK MATERIAL IS 14 GAGE SERIES 400 STAINLESS STEEL, CONTINUOUSLY BUTT WELDED EXHAUST STACK.
 3. DIMENSIONS "H" AND "W" ARE THE O.D. OF THE EXHAUSTER DISCHARGE.

C000541B

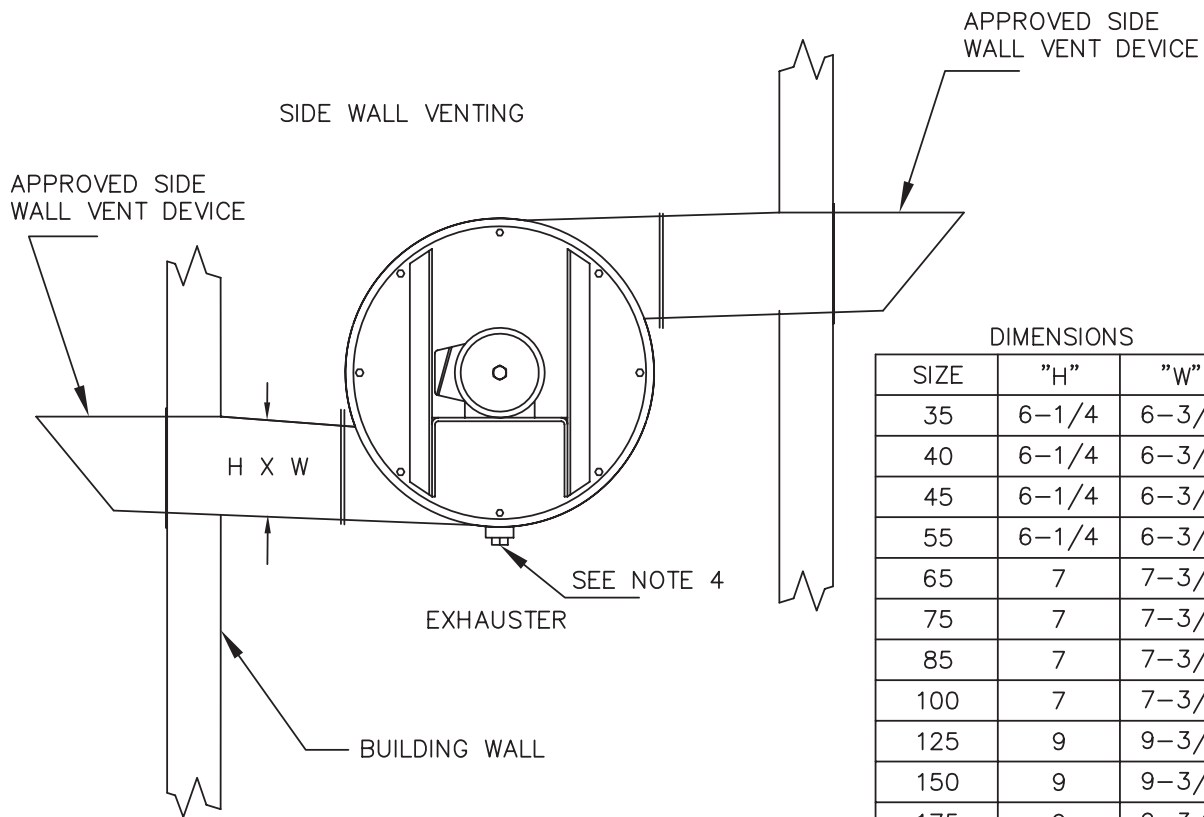

DIMENSIONS

SIZE	"H"	"W"
35	6-1/4	6-3/8
40	6-1/4	6-3/8
45	6-1/4	6-3/8
55	6-1/4	6-3/8
65	7	7-3/8
75	7	7-3/8
85	7	7-3/8
100	7	7-3/8
125	9	9-3/8
150	9	9-3/8
175	9	9-3/8
200	9	9-3/8
250	10-5/8	11-1/8
275	10-5/8	11-1/8
300	10-5/8	11-1/8
325	10-5/8	11-1/8
350	10-5/8	11-1/8
400	10-5/8	11-1/8
500	10-5/8	11-1/8
600	10-5/8	11-1/8

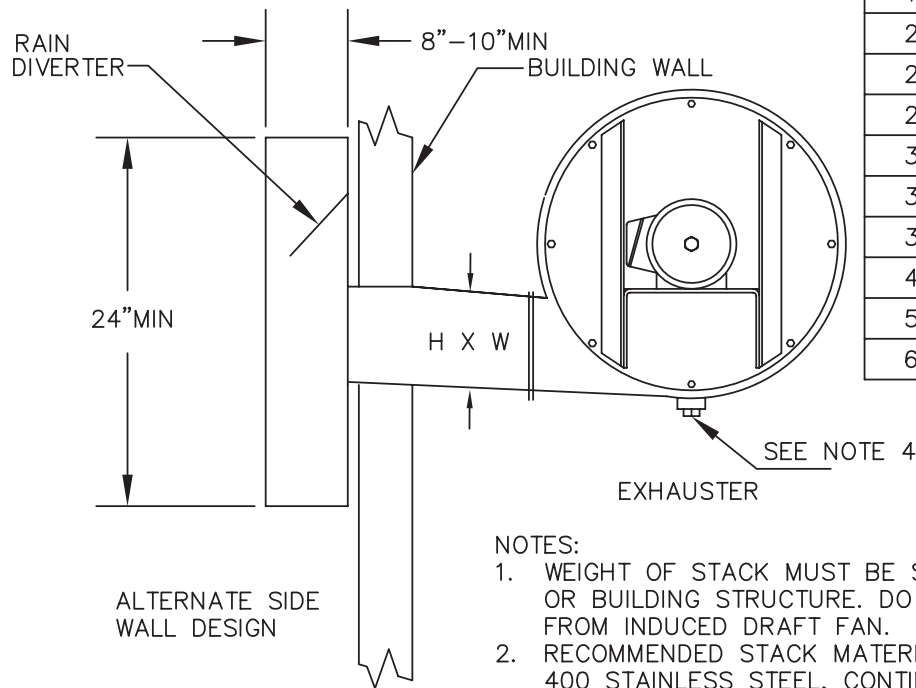

NOTES:

1. WEIGHT OF STACK MUST BE SUPPORTED FROM FLOOR OR BUILDING STRUCTURE. DO NOT SUPPORT STACK FROM INDUCED DRAFT FAN.
2. RECOMMENDED STACK MATERIAL IS 14 GAGE SERIES 400 STAINLESS STEEL, CONTINUOUSLY BUTT WELDED EXHAUST STACK.
3. PITCH HORIZONTAL RUNS UPWARD 1/4 INCH PER FOOT TOWARD OUTLET FOR CONDENSATE DRAINAGE. SUPPORT HORIZONTAL RUNS AS REQUIRED TO PREVENT SAGGING.
4. FOR NON HIGH TURNDOWN BURNERS, WHENEVER USING SIDE WALL VENTING, A DRAIN LINE SHOULD BE ADDED TO THE BOTTOM OF THE EXHAUSTER HOUSING FOR CONDENSATE REMOVAL.
5. DIMENSIONS "H" AND "W" ARE THE O.D. OF THE EXHAUSTER DISCHARGE.

C000563B

Pitch horizontal pipes upward ¼ inch per foot toward outlet for condensate drainage. Support horizontal runs as required to prevent sagging.

Vents should terminate that would not cause a down draft to occur. This could affect the negative pressure required in the heat exchanger. Do not install dampers or other restrictive devices in the flue vent pipe.

The stack should not be installed in such a manner that access to the components is obstructed. Guy wires may be required to brace the stack above rooflines.

Outdoor units are supplied with a stack. The stack shall have a minimum of at least 36" clearance to combustible materials.

WARNING: CARBON MONOXIDE! Your venting system must not be blocked by any snow, snow drifts, or any foreign matter. Inspect your venting system to ensure adequate ventilation exists at all times! Failure to heed these warnings could result in carbon monoxide poisoning (symptoms include grogginess, lethargy, inappropriate tiredness, or flu-like symptoms).

G. Field Piping Gas Piping

All gas piping must be in accordance with the requirements outlined in the National Fuel Gas Code – ANSI Z223.1. It is required that a ground union be installed adjacent to the manifold for easy servicing. A drip leg and/or filter should be provided upstream of the unit's inlet gas connection. An additional shut-off must be located external of the unit's enclosure where required by local code. The location of this valve must comply with all local codes. A 1/8 inch N.P.T. plugged tapping, accessible for test gauge connection, must be installed immediately upstream of the gas supply connection to the unit.

WARNING: To avoid equipment damage or possible personal injury, do not connect gas piping to this unit until a supply line pressure/leak test has been completed. Connecting the unit before completing the pressure/leak test may damage the unit gas valve and result in a fire hazard.

DANGER: Never use an open flame to detect gas leaks. Explosive conditions may exist which would result in personal injury or death.

The gas line should be supported so that no strain is placed on the unit. Pipe compounds, which are not soluble to liquid petroleum gases, should be used on threaded joints.

Refer to the heater's rating plate to determine the minimum gas supply pressure for obtaining the maximum gas capacity for which this heater is specified.

Refer to the heater's rating plate to determine the maximum supply pressure to the heater.

The appliance and its individual shutoff valve must be disconnected from the gas supply piping system during any pressure testing of that system at test pressures in excess of ½ PSIG.

The appliance must be isolated from the gas supply piping system by closing it's individual manual shutoff valve during any pressure testing of the gas supply piping system at test pressure equal to or less than ½ PSIG.

Correctly sized piping must be run to the unit.

Please note that gas line pressure must be as shown on specification plate when unit is operating at full input. The high-pressure regulator and relief valve should be, if possible, mounted at least 5 to 10 feet upstream from the appliance regulator on the unit (if applicable).

Building Pressure Transducer Piping (PT-13)

Pipe the high side to location inside the building that will not be affected by air movement. Pipe the low side to the atmosphere, positioned so it will not be affected by the wind and not exposed to the elements. Be sure that all tubing is clean and clear of any debris before installing tubes on the transducer.

Regulator Venting

NOTE: Regulators and devices that have vent limiting orifices installed do not require a vent line.

- a.) Keep the vent line length as short as possible to minimize the restriction and reduce the vent's tendency to cause regulator pulsation .
- b.) Never use pipe sizes smaller than the vent size; smaller pipe sizes restrict the gas flow. If a long gas vent line length must be used, you should increase the pipe one nominal size for every ten feet of run to keep the flow restriction as low as possible.
- c.) Support the vent line to eliminate strain on the regulator diaphragm case.
- d.) Always point outdoor vent lines in the downward position to reduce the possibility of rain, snow, sleet, and other moisture entering the pipe. Install a bug screen in the end on the vent line.
- e.) Do not locate the vent line terminus near windows, fans, or other ventilation equipment.
- f.) Adhere to all applicable codes and regulations.
- g.) If your vent line causes regulator pulsation, consult your local sales representative or the factory.
- h.) We strongly recommend running a separate vent line for each regulator. Headers with various installed devices can cause regulator malfunction.

CAUTION: Ensure the vent line is away from ANY potential ignition sources. It is the installer's responsibility to ensure the vent line is exhausting to a safe environment.

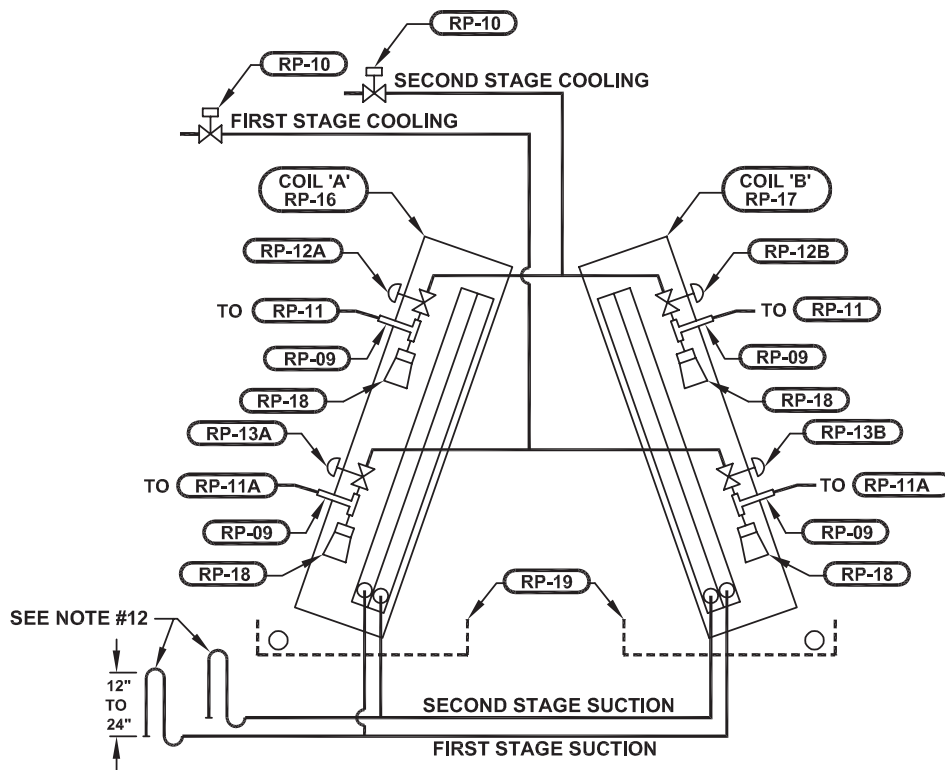

A-FRAME COIL ASSEMBLY END ELEVATION

THE ABOVE PIPING SCHEMATIC SHOULD BE USED AS A GUIDE ONLY. PROPER ENGINEERING DESIGN OF THE OVERALL REFRIGERATION SYSTEM MAY DICTATE AN ALTERNATE PIPING SCHEMATIC BE USED TO THE ONE ILLUSTRATED ABOVE.

GENERAL NOTES:

1. RECOMMEND FIRST STAGE AND SECOND STAGE OF COOLING BE PROVIDED WITH HOT GAS BYPASS.
2. ALL PIPING TO BE ACR TYPE 'L' COPPER.
3. ALL PIPING TO BE PITCHED IN THE DIRECTION OF REFRIGERANT FLOW. PITCH TO BE 1 INCH PER 10 FEET.
4. ALL SUCTION LINES TO BE INSULATED.
5. LIQUID LINE FILTER/DRIER, SIGHT GLASS, SUCTION LINE FILTER/DRIER, ISOLATION VALVES, FITTINGS, DISCHARGE VIBRATION ABSORBER, ACCUMULATORS AND OTHER AVAILABLE SYSTEM OPTIONS ARE NOT SHOWN.
6. RECOMMEND LONG RADIUS ELBOWS BE USED TO MINIMIZE SYSTEM PRESSURE DROP.
7. RECOMMEND LIQUID LINES FOR R-410A BE SIZED FOR A MAXIMUM PRESSURE DROP OF 6 PSIG.
8. RECOMMEND SUCTION LINES FOR R-410A BE SIZED FOR A MAXIMUM PRESSURE DROP OF 3 PSIG.
9. RECOMMEND CONDENSER SUBCOOLING CIRCUIT FOR R-410A BE CAPABLE OF SUBCOOLING LIQUID BETWEEN 12 TO 19°F.
10. CONNECT 1/4" O.D. EXTERNAL EQUALIZING LINE GENERALLY LOCATED IN EACH SUCTION HEADER OF EACH DX COIL TO THE APPROPRIATE THERMAL EXPANSION VALVE (TXV).
11. SENSING BULB FROM THERMAL EXPANSION VALVE (TXV) TO BE LOCATED ON THE SIDE OF A HORIZONTAL PORTION OF THE DX COILS' SUCTION LINE PIPING AT AN ANGLE OF APPROXIMATELY 120° FROM VERTICAL. DO NOT LOCATE SENSING BULB ON ANY PIPING USED IN A TRAP OR DOWNSTREAM OF A TRAP.
12. INSTALL TRAP IN SUCTION LINE AS ILLUSTRATED IF COMPRESSOR IS WITHOUT PUMP DOWN AND IS LOCATED BELOW THE THE DX COIL.
13. ALL COIL SPECIALTIES AND REFRIGERANT PIPING SHOWN OTHER THAN THE REFRIGERANT DISTRIBUTOR AND ANY OTHER REQUIRED REFRIGERATION SYSTEM SPECIALTIES ARE TO BE PROVIDED BY AND INSTALLED IN THE FIELD BY OTHERS.

COMPONENT IDENTIFICATION

RP-09	HOT GAS BYPASS TEE
RP-10	LIQUID LINE SOLENOID VALVE
RP-11	HOT GAS BYPASS VALVE - SECOND STAGE
RP-11A	HOT GAS BYPASS VALVE - FIRST STAGE
RP-12A	THERMAL EXPANSION VALVE (TXV-1A) CIRCUIT #2 - COIL 'A'
RP-13A	THERMAL EXPANSION VALVE (TXV-2A) CIRCUIT #1 - COIL 'A'
RP-12B	THERMAL EXPANSION VALVE (TXV-1B) CIRCUIT #2 - COIL 'B'
RP-13B	THERMAL EXPANSION VALVE (TXV-2B) CIRCUIT #1 - COIL 'B'
RP-16	DX EVAPORATOR COIL 'A' - INTERTWINED
RP-17	DX EVAPORATOR COIL 'B' - INTERTWINED
RP-18	REFRIGERANT DISTRIBUTOR
RP-19	CONDENSATE PAN PROVIDED WITH DRAIN CONNECTIONS ON BOTH ENDS

P000971R410A

Refrigerant Piping

Refer to drawing on following page.

H. Field Wiring and Remote Control Installation

1. If the optional low temperature controller was not an integral part of the heater, the factory recommends that a low temperature limit control be installed in areas where freeze protection is needed in the event of burner shut down.
2. Connect the power lines to the line side of the power distribution block or optional main disconnect switch.
3. Field wiring is indicated on the wiring diagram, typically dashed lines. Where field wiring of the control circuit is required, take care to size the wires for a maximum 10% voltage drop. The VA rating of the transformer should be the maximum load.
4. Mount and wire remote control panel, thermostat temperature sensors, and any other field-installed controls as indicated on the unit control-wiring diagram.
5. Connect all wiring to the appropriate field wiring terminal and any shielded or twisted wires as indicated on the unit control-wiring diagram.
6. Field wiring shall have a temperature rating of at least 105°C. The minimum size of the supply cable circuit shall be sufficient for the maximum ampacity of the heater.

NOTE: Burner and exhaustor motor wiring must be connected to the corresponding starter. As each motor and starter are sized as a matched set, incorrectly wired components may cause some motors to have nuisance shutdowns and others will not have proper overload protection.

I. Locating Temperature Controls

The room or outdoor thermostats should be mounted where they will not be subjected to direct impact of the heated air or radiant heat from the sun. It is also recommended that thermostats, especially those with mercury bulb contacts, be mounted on a vibration free surface. The sides of building columns away from the heater or interior walls are usually the location best suited for mounting thermostats.

Controls with outdoor bulbs require that the outdoor bulb be shielded from direct radiation from the sun. Unit mounted sensors are factory located and mounted.

J. Drains and Traps

Some furnaces maybe supplied with condensation removal pipe connections. Condensate from the heat exchanger is acidic and may contain chemical compounds requiring special drainage. The drain must be installed in accordance with all plumbing codes. The condensate is to be drained via PVC or steel pipe with an indirect connection to the plumbing wastes. Where a condensate

neutralizer is used, an overflow shall be provided such that condensate will be directed to the drain in the event that the neutralizer becomes plugged. Indoor units typically require a condensate trap to be installed to prevent combustion gasses entering the space. Outdoor units may require installing a heat-trace or special attention to drains to prevent freezing and clogging of the drain line.

Since the condensate is drained by gravity, avoid long runs of drain piping. If a long run of trapping cannot be avoided or the piping has water flow restrictions such as several elbows, and extra height to provide enough hydrostatic head to overcome the frictional losses. Always slope piping down a minimum of 1/8" per foot in the direction of the flow.

Evaporator Coil – Draw Through

The cooling coil section can be located in the unit so that supply air is drawn through the evaporative coil(s). This results in the condensate being induced to the area of low static pressure. Unless some means of pressure equalization is provided in the condensate drain, the air rushing through the drain will cause the condensate to accumulate in the drain pan. As the unit continues to operate, the accumulated water will be picked up by the in-rushing air and carried with the air over the side of the drain pan causing possible water leaks into the supply duct and/or through the bottom of the unit causing water damage in the building. A trap should be installed to prevent this condensate water buildup. **See drawing on next page.**

Evaporator Coil – Blow Through

The cooling coil section can be located in the unit so that supply air is blown through the evaporative coil(s). A properly piped trap should be installed to control the condensate flow from the unit and also eliminate conditioned air from being blown out the condensate drain. **See drawing on next page.**

On initial start-up, it may be necessary to fill the trap manually or, after unit has operated sufficiently for a small amount of condensate to collect in the drain pan, turn off the unit and the trap will automatically fill.

During the winter months when the cooling system is turned off and the unit is exposed to freezing conditions, an antifreeze solution should be poured into the condensate pan trap to prevent freezing and possible damage. The condensate drain trap may also be drained and capped, but be sure to remove the cap when starting the cooling for the next season.

**SUGGESTED P-TRAP DESIGN FOR CONDENSATE
DRAIN PANS UNDER A NEGATIVE PRESSURE**

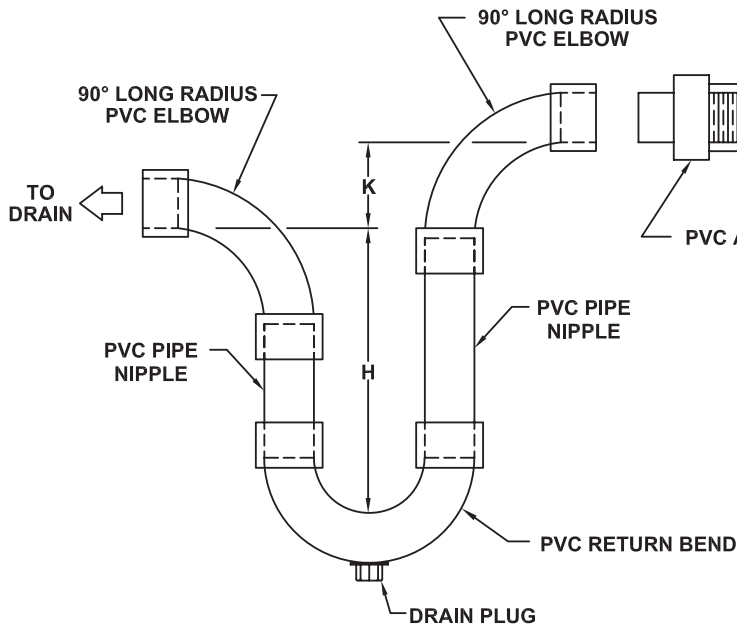

NOTE:
'H' TO BE A MINIMUM OF
1/2" PLUS THE TOTAL SYSTEM
STATIC PRESSURE ("W.C.).

'K' TO EXCEED THE NEGATIVE
STATIC PRESSURE IN "W.C. OF
THE SECTION OF THE UNIT
WHERE THE DRAIN IS INSTALLED
AND DOUBLE WHEN SPACE
PERMITS.

(10/30/09 C000659B)

**SUGGESTED P-TRAP DESIGN FOR CONDENSATE
DRAIN PANS UNDER A POSITIVE PRESSURE**

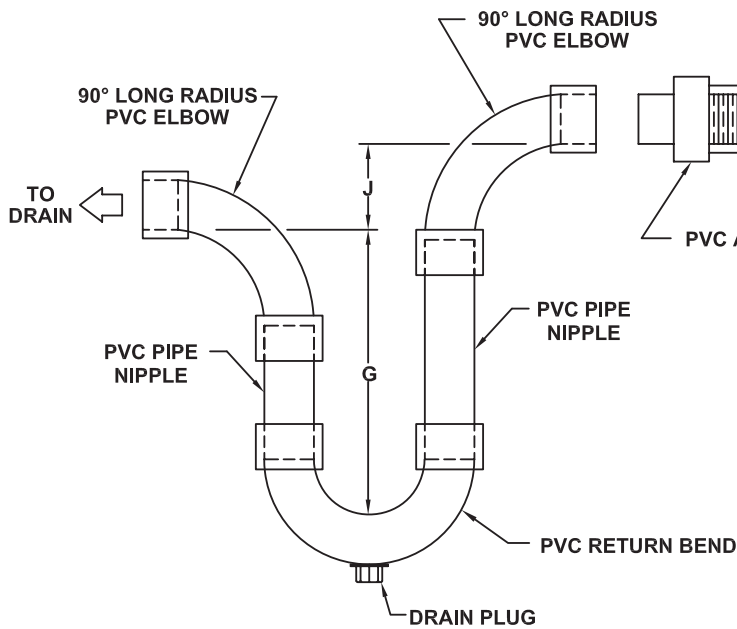

NOTE:
'G' TO BE A MINIMUM OF
1/2" PLUS THE TOTAL SYSTEM
STATIC PRESSURE ("W.C.).

'J' TO EXCEED THE POSITIVE
STATIC PRESSURE IN "W.C. OF
THE SECTION OF THE UNIT
WHERE THE DRAIN IS INSTALLED.

(10/30/09 C000659B)

NOTE:

- ALL SUPPLIED CONDENSATE DRAINS MUST BE PIPED.
- ON OUTDOOR VERTICAL UNITS, WHERE THE COIL SECTION IS INSTALLED ON TOP OF A HEATING SECTION, IT IS EASIEST TO INSTALL AN ELBOW IN THE CONDENSATE DRAIN NIPPLE ON THE WEATHERPROOF ENCLOSURE SIDE BEFORE THE UNIT IS STACKED.

08/06/18 C000659C

SECTION IV – PRE START-UP

Do not attempt start-up without completely reading and understanding this manual, along with the Digital Control System user manual (if applicable).

Pre Start-Up

The owners representative or equipment operator should be present during start-up to receive instructions on care and adjustments of the equipment.

All equipment has been factory tested, adjusted, metered and inspected to meet conditions set at the time the order was placed. Only minimal adjustments should be required. All information in this service manual is typical. All products are semi-custom and changes may occur.

CAUTION: Line side of disconnect may be energized. Follow proper “lockout/tagout” procedures.

NOTE: A qualified service engineer should perform all servicing and adjustments of the Indirect Gas-Fired unit.

Perform a visual inspection, internally and externally, to make sure no damage has occurred and that everything is secure. This inspection is very important and should be completed with great care given to detail. A good pre-start inspection will insure against possible unit damage on start-up and will save valuable analysis time.

1. Check that the physical condition of the unit exterior is acceptable.
2. Check that any insulation inside the unit is properly secured.
3. Remove all shipping blocks, brackets and bolts from supply fan base with optional isolation base.
4. Check all terminals for loose connections and inspect all wiring terminations to insure that all crimped connections are tight.
5. Inspect all fan and motor bearings and lubricate if necessary.

CAUTION: DO NOT RUPTURE GREASE SEALS.

6. Inspect pulleys and belts for tightness, tension and alignment. **Do not overtighten belts.**
7. Check set screws on all bearings, pulleys, fans and couplings for tightness.
8. Check voltage supplied to disconnect switch; the maximum voltage variation should not exceed + 10%. Phase voltage unbalance must not exceed 2%.
9. Check thermostat(s) for normal operation.
10. Check that system duct work is installed and free of obstructions.
11. Check that fans turn freely in housing.
12. Check that the area around the unit is clear of flammable vapors or containers of flammable liquids.
13. Check that all piping connections, particularly unions, are tight. Check all gas piping for leaks using a soap

bubble solution. The most common types of problems found relative to the gas train itself is free of foreign material within the gas piping. This will interfere with the proper operation of the gas train components and burner. Purge all air from gas lines per gas codes.

14. Check that all accessories requiring field wiring have been properly installed.
15. Check burner for proper location and alignment.
16. Check that filters, filter stops, accessories and any ship loose items are installed properly.
17. Check that vent lines (if applicable) are run to atmosphere on gas regulators and pressure switches for indoor units. Vent lines should terminate outside the building, with a turndown elbow and bug screen. Note that some units will use vent limiters and vent lines are not required. If vent lines are even partially plugged, this will interfere with proper venting of pressure control devices.
18. Check that all manual gas shut-off valves are closed.
19. When failure or malfunction of this heater creates a hazard to other fuel burning equipment, (e.g. when the heater provides make-up air to a boiler room), the heater is to be interlocked to open inlet air dampers or other such devices.
20. Motor overload relay setting should match the motor's nameplate full load amperage.
21. Check any dampers or mixing boxes (if supplied). Make sure all damper linkage is free to move and no binding will occur. If dampers are of the modulating type, check control capillary tubes to insure that the tubes and bulbs are in the proper location and will not rub against any other parts.
22. Check to ensure all manual reset safety devices have been reset and limits are in the normal operating position.
23. Check to ensure the flue stack is installed properly and is free of obstructions.
24. Adjust the induced draft damper so it is approximately 75% open.
25. Remove shipping screw from rear relief door (if applicable).
26. Check that all fuses are installed.
27. Check that inlet gas pressure is the same as shown on the rating plate.
28. Check that field wiring connections to the burner motor and draft inducer motor are connected to the correct starters.
29. Check to make sure the inlet gas pressure is the same as the rating plate.

SUGGESTED TOOLS AND INSTRUMENTS

Volt/Ohm meter
 Tachometer
 Stack & Temperature Thermometer
 Gas Pressure Gauge (0 – 35 lbs.)
 Ammeter/Amprobe (or equal)

U-Tube Manometer (0 – 10" W.C.) Two Required
 Flue Gas Test Equipment
 Standard Hand Tools
 D.C. Volt Meter
 BAC View 6 (KP-01) or Equipment Touch (KP-02) for
 DDC Controls (if applicable)

SUGGESTED CONTROLS SETTINGS

FL-01 Fan Control.....	95° – 110°F	RE-21 Time Clock.....	Customer Discretion
FL-02 High Limit (IFR Down Discharge).....	165° F	TC-01 Room Thermostat	Customer Discretion
FL-02 High Limit (All Other Units).....	200° F	TC-02 Modulating Discharge Ductstat.....	70° F
FL-04 Auxiliary High Limit (IFR Down Discharge)..	175° F	TC-03 On-Off Inlet Ductstat.....	65° F
FL-04 Auxiliary High Limit (All Other Units).....	210° F	TC-06 High Limit Discharge Ductstat.....	100° F
PS-01 Draft Proving Switch.....	Adjust to field condition	TC-07 Low Limit Discharge Ductstat.....	60° F
PS-02 Burner Proving Switch.....	Adjust to field condition	TC-08 Freeze Thermostat.....	45° F & 3 Minutes
PS-04 Low Gas Pressure Switch.....	1.0" W.C.	TC-55 Return Air Ductstat.....	Customer Discretion
PS-07 High Gas Pressure Switch.....	125% above burner firing rate	TC-58 Night Setback Thermostat....	Customer Discretion
PS-10 Main Air Proving Switch	Adjust to field condition		
PS-12 Clogged Filter Switch.....	Adjust to field condition		

SUGGESTED CONTROLS SETTINGS FOR OPTIONAL DDC CONTROLS

(Refer to Digital Control System user manual for default settings)

TS-02 Space Temperature Sensor..	Customer Discretion	MP-05 Damper Control Potentiometer.....	Customer Discretion
KP-01 Keypad/Display Module	Customer Discretion		
KP-02 Touchscreen Module	Customer Discretion	MP-15 Unit Enable Potentiometer...Customer Discretion	
		PT-13 Building Pressure Transducer.....	Adjust to Field Condition

BEFORE ATTEMPTING TO START THE HEATER, READ THE TYPICAL SEQUENCE OF OPERATION AS SHOWN BELOW:

Typical Sequence Of Operations Note: This sequence is written for only the burner safety and operating portion of the heater. Other control systems for dampers, mixing boxes, and temperature controls are included in the unit typical sequence of operation and / or wiring diagram:

1. With main supply air fan(s) on, thermostat setpoint calling for heat, and all switches and operating controls in their normal position, the exauster motor and burner motor will run and "pre-purge" the combustion chamber. Pre-purge timing is not adjustable and is approximately 90 seconds.
2. With pre-purge timing complete, the pilot solenoid valve and ignition transformer are energized. The pilot flame will be established and sensed by the flame sensor.
3. Ignition transformer is de-energized and pilot valve remains on.
4. Main fuel valve(s) will open. The main burner flame will be established.
5. Pilot valve is de-energized. (This is only on heaters with interrupted pilots).
6. Once thermostat setpoint is satisfied, the main fuel valve(s), burner motor, and exauster motor will be de-energized. Main supply air fan(s) will continue to run.

SECTION V – UNIT START-UP WITHOUT DDC CONTROLS

Before attempting to start the heater read and understand the sequence of operations, electrical schematic, gas train, burner, and flame safeguard control.

WARNING: During installation, testing, servicing and trouble shooting of this product, it may necessary to work with live electrical components. Have a qualified licensed electrician or other individual who has been properly trained in handling live electrical components to perform these tasks. Failure to follow all electrical safety precautions when exposed to live electrical components could result in death or serious injury.

Make sure all manual gas valves are closed.

Make sure all doors and service panels have been closed or replaced.

Turn main disconnect switch off. Check the incoming line voltage to match unit nameplate rating. If voltage is over +10% of nameplate rating or phase voltage unbalance is over 2%, notify contractor or power company.

If power supply meets requirements turn main disconnect switch on. Turn Fan “on-off” switch to “on” position. Inlet shut-off damper(s) (if applicable) opens, after end switch has proven damper is open the blowers or props run.

Turn Fan “on-off” switch to “off” position. Check supply fans for proper rotation. The burner and induced draft fan rotation can be checked when the heat section is started.

NOTE: To change rotation of the fans, simply interchange any two (2) of the line leads of the motor starter for 3 phase motors. On single-phase motors, refer to motor nameplate.

Turn Fan “on-off” switch to “on” position. Check for proper fan RPM. Check that all amp draws do not exceed nameplate ratings and overloads are set to nameplate amps.

Check to make sure all dampers and controls are working properly.

Turn Fan “on-off” switch to “off” position.

NOTE: When setting up the burner for the first time or if the appliance has been shut down for an extended period of time, these same start up procedures should be followed.

Open pilot and first main gas shut-off valves **slowly**.

Last main gas shut-off valve before the burner must remain closed at this time. Reset high-low gas pressure switches (if applicable). Check pilot and main gas lines for leaks using soap solution.

Check the gas supply pressure by replacing the plug fitting on the pilot gas line with a pressure gauge with appropriate range. Check that pressure reading is within the specified range on the rating plate.

NOTE: To adjust gas pressure on supply lines where a regulator has been installed (to set inlet pressure to rating plate maximum pressure), remove dust cap of main gas regulator and turn adjusting screw clockwise to increase pressure or counterclockwise to decrease pressure.

Setting the Pilot Flame

CAUTION: Do not attempt to start the pilot when furnace is full of vapor or combustion chamber is very hot.

CAUTION: At no time should you stand in front of the relief door.

Honeywell Flame Safeguard Control (RE-02)

A keyboard display module (Honeywell #S7800A1142) is recommended to read the flame signal, and is a good troubleshooting device. A V.O.M. can also be used on the D.C. voltage test jacks marked “+” and “-” on flame amplifier.

Connect manometer to pilot test tee (if applicable).

Set all thermostats to call for heat. Set inlet ductstat (if applicable) above outside air temperature.

Turn Fan and Heat-Off-On switches to the On position and check rotation of burner and induced draft fans, amps, and overload settings. Make sure the damper on the induced draft fan is approximately 75% open.

If limits and all safety controls are closed, the burner and induced draft fan will run for 90 seconds before ignition trial as a pre-purge cycle.

Place run/test switch on the flame safeguard relay in the “test” position during P.F.E.P.

NOTE: Pilot regulator adjustment may be needed if the adjustment of the needle valve does not yield the required reading. Typical adjustment of the needle valve is 1-1/2 to 2 turns open.

NOTE: Frequently the cause of pilot problems relates to gas pressures that are too high and/or air dampers that are closed too far. This causes a fuel rich mixture.

NOTE: 3 or 4 trials may be needed to purge air from pilot line.

Watch D.C. voltmeter carefully. The reading should be steady and between 2.0 and 5.0 Volts D.C. If the reading is too low, slowly turn the needle valve in or out until satisfactory flame signal is obtained (See separate literature for testing of flame safeguard).

Make sure that the combustion air and pilot gas pressure is sufficient to provide instant ignition, a stable flame, and flame signal. Cycle pilot several times to insure reliability.

With pilot adjusted, you can now shut down the burner by turning the Heat "on-off" switch to the "off" position.

Setting the Main Flame

IMPORTANT: When the Flame Safeguard relay module is switched to the TEST mode, it stops and holds at the next Run/Test Switch point in the operating sequence. Make sure that the Run/Test Switch is in the Run position before starting the burner.

CAUTION: Do not attempt to start the burner when furnace is full of vapor or combustion chamber is very hot.

CAUTION: At no time should you stand in front of the relief door.

Connect the test instruments, meters, and thermometers on the heater and controls to measure and record the appropriate data.

Install one manometer at test port on the last tee of the burner manifold and one at the relief door.

Set all thermostats to call for heat. Set inlet ductstat (if applicable) above outside air temperature.

Restart unit. After the pilot proves the main automatic fuel valves will be energized. **Slowly** open the last gas shut-off valve and the burner should light immediately.

CAUTION: If main flame does not light within a few seconds after pilot flame is established, shut the burner down and repeat steps. You may have to eliminate air from the main gas line. The main gas pressure and / or burner air setting may also need to be readjusted.

If flame signal drops significantly when main gas valves open, slightly increase or decrease pilot gas pressure to attain a steady flame signal.

After the burner lights; adjust gas pressure regulator, using a manometer, and combustion air damper to match normal manifold pressure shown on unit nameplate. Make sure the thermostat and gas valves are in high fire.

These units have an induced draft fan, a minimum of -0.20" W.C. must be maintained at the relief door, simultaneously while setting the fuel to air pressure on the burner at full input. This is done by changing the damper setting at the induced draft fan outlet with a warm stack. Be sure to lock down the locking quadrant when you are done.

Check all gas piping again for leaks using a soap bubble solution.

On-Off Operation

Check to make sure operating thermostat cycles burner and induced draft fan.

See final checks and adjustments.

High-Low-Off Operation

Turn the two stage thermostat down slowly until main gas valve begins to drive closed (low fire) or the power on the second stage may be disconnected.

NOTE: Low fire rate should be set at approximately 50% of high fire.

CAUTION: Too low of an input setting will cause condensation of the flue gases.

To reset low fire, remove the cover from the Two Stage gas valve actuator and using the wrench provided readjust the internal cam setting.

Check to make sure Two Stage thermostat cycles burner and induced draft fan.

See final checks and adjustments.

Modulating Operation

Set high fire by adjusting main gas regulator and by the high fire adjusting screw on the butterfly valve.

Observe flame as burner modulates when thermostats are adjusted.

NOTE: Flame should modulate slowly and evenly throughout the entire travel, although flame may become somewhat “dirty” during travel. If stopped at any point, proper combustion should resume.

Turn all modulating thermostats to their lowest setting without turning the burner off, or with power off remove the coil wire on low fire hold relay and restart burner.

Set low fire with the low fire adjusting screw on the butterfly valve.

Observe low fire, it should be substantial enough to maintain proper combustion and be within the designed turndown range of the burner.

CAUTION: Too low of an input setting will cause condensation of the flue gases, this should be avoided unless condensate drains are provided.

See following drawings for operation of modulating thermostat and typical circuit. SW-11/SW-13 should cycle the burner.

See final checks and adjustments toward the end of this section.

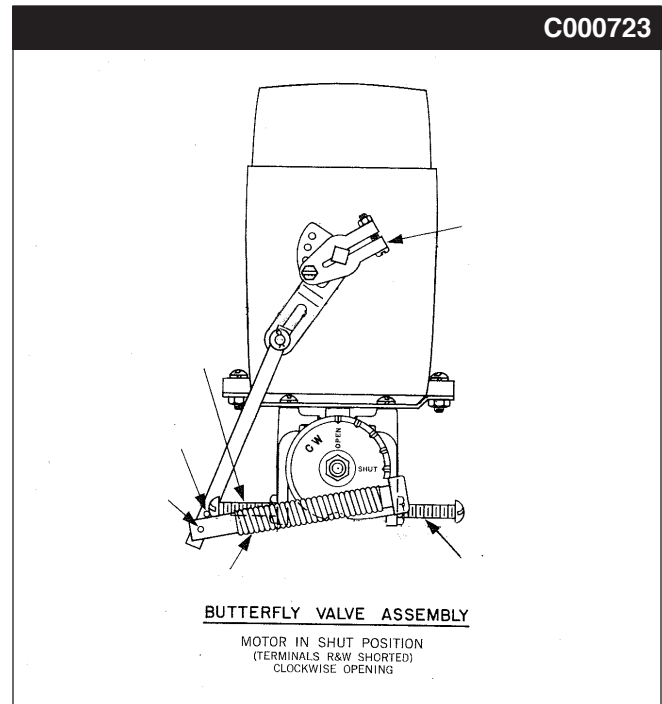

TYPICAL SEQUENCE FOR MODULATING THERMOSTAT WITH 135 OHM CONTROLS

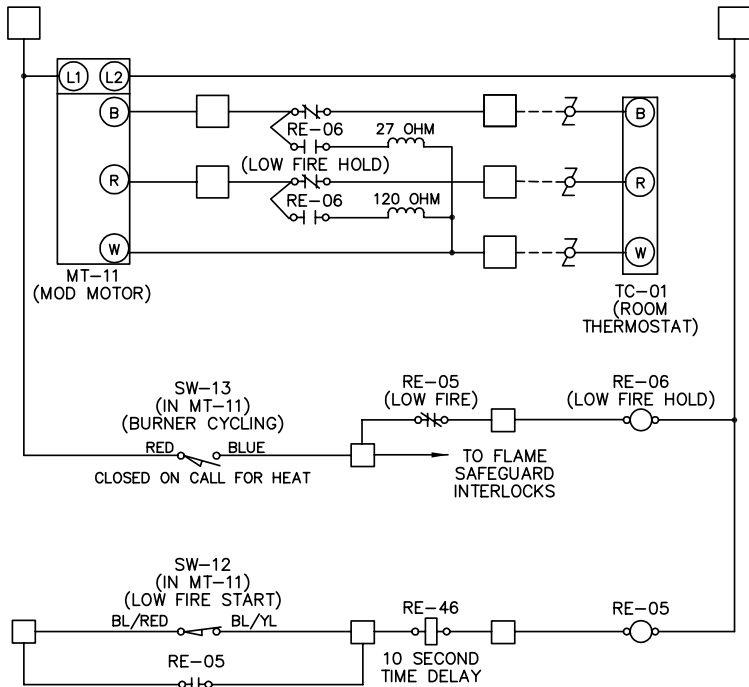

NOTES

1. RESISTORS ARE SIZED TO HOLD MODULATING MOTOR AT APPROXIMATELY 25° OF MOTOR TRAVEL FOR LOW FIRE START.
2. SW-13 (BURNER CYCLING SWITCH) IS MADE 20° TO 90° OF MOTOR TRAVEL.
3. SW-12 (LOW FIRE START SWITCH) MADE 0° TO 30° OF MOTOR TRAVEL.

OPERATION

1. STAT CALLS FOR HEAT DRIVING MT-11 OPEN.
2. WHEN MT-11 REACHES 20° OPEN, SW-13 CLOSES.
3. SW-13 POWERS RE-06 AND PLACES MT-11 UNDER RESISTOR CONTROL.
4. MT-11 MOVES TO 25° OPEN AND REMAINS THERE DURING TRAIL FOR IGNITION.
5. UPON PROOF OF FLAME RE-05 DE-ENERGIZES RE-06
6. MT-11 IS TRANSFERRED BACK TO CONTROL.
7. WHEN MT-11 OPENS TO 30°, SW-12 WILL OPEN.
8. RE-05 CONTACTS FORM A BY-PASS CIRCUIT AROUND SW-12

MOVE SCREWDRIVER AT TOP ONLY TO ADJUST CAM

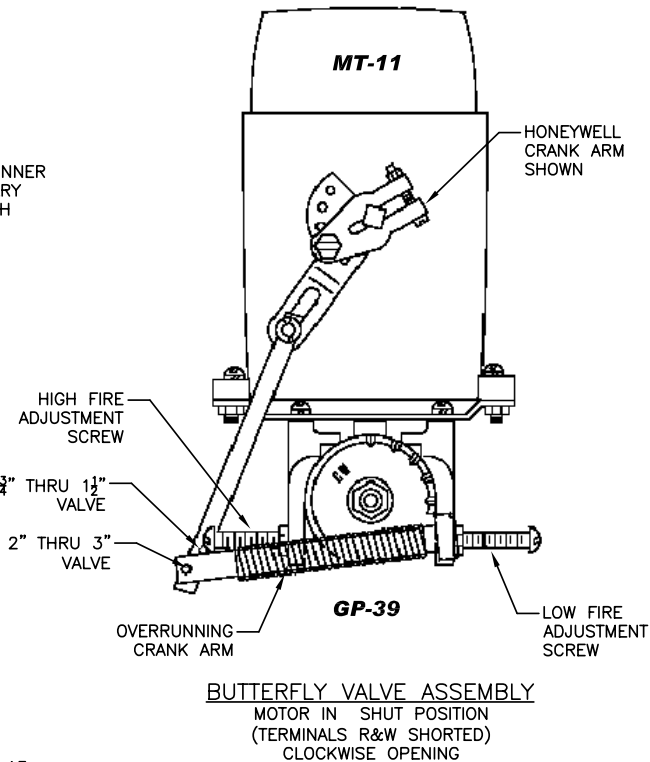
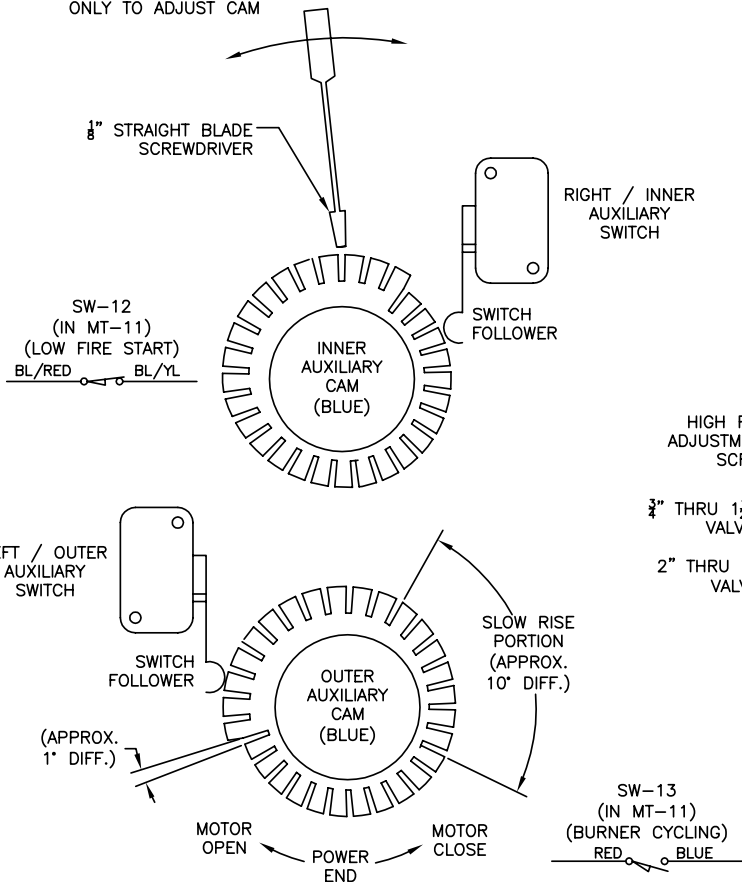

C000710

TYPICAL SEQUENCE FOR MODULATING THERMOSTAT WITH 4-20 mA CONTROLS

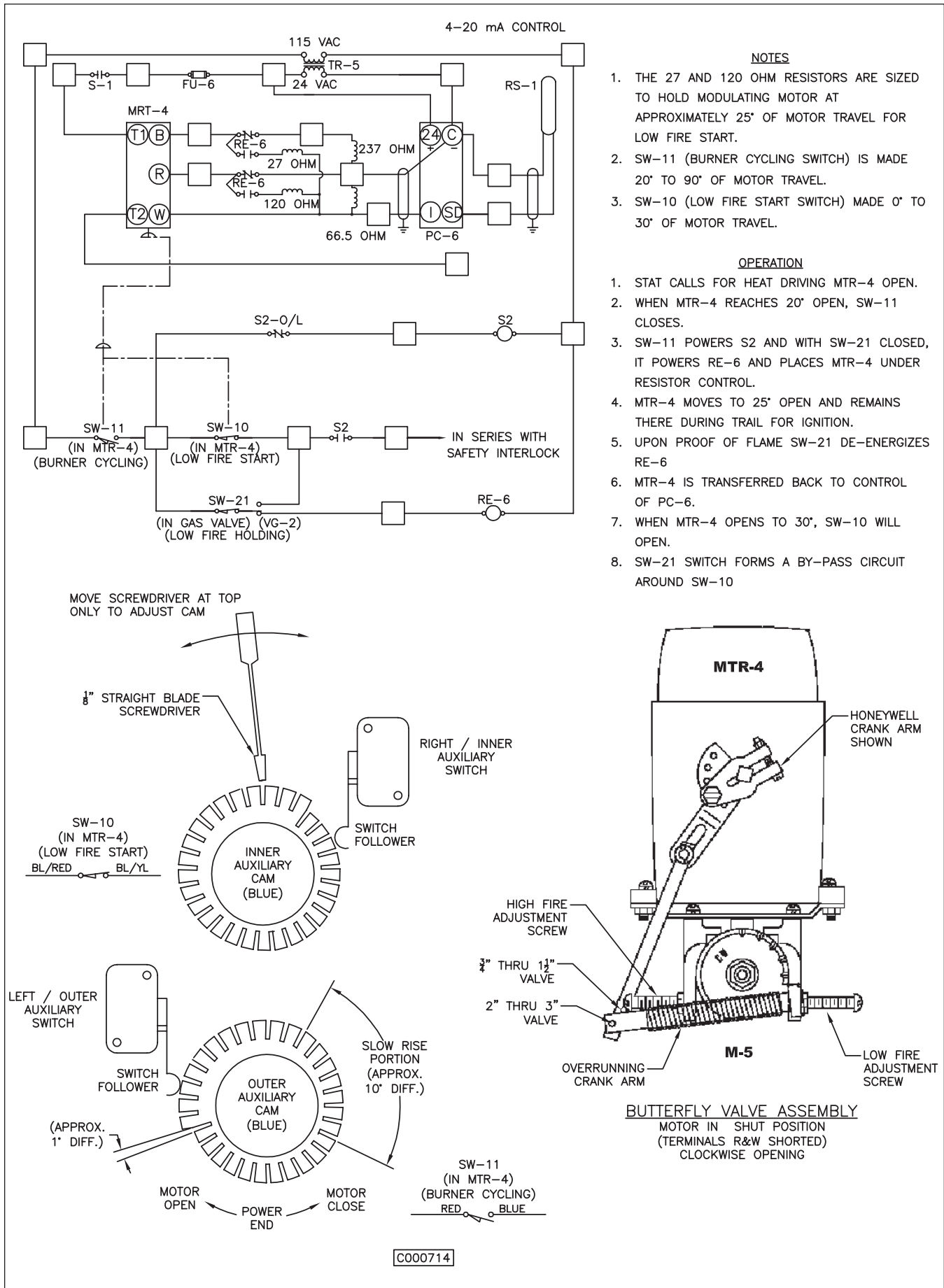

NOTES

1. THE 27 AND 120 OHM RESISTORS ARE SIZED TO HOLD MODULATING MOTOR AT APPROXIMATELY 25° OF MOTOR TRAVEL FOR LOW FIRE START.
2. SW-11 (BURNER CYCLING SWITCH) IS MADE 20° TO 90° OF MOTOR TRAVEL.
3. SW-10 (LOW FIRE START SWITCH) MADE 0° TO 30° OF MOTOR TRAVEL.

OPERATION

1. STAT CALLS FOR HEAT DRIVING MTR-4 OPEN.
2. WHEN MTR-4 REACHES 20° OPEN, SW-11 CLOSES.
3. SW-11 POWERS S2 AND WITH SW-21 CLOSED, IT POWERS RE-6 AND PLACES MTR-4 UNDER RESISTOR CONTROL.
4. MTR-4 MOVES TO 25° OPEN AND REMAINS THERE DURING TRAIL FOR IGNITION.
5. UPON PROOF OF FLAME SW-21 DE-ENERGIZES RE-6
6. MTR-4 IS TRANSFERRED BACK TO CONTROL OF PC-6.
7. WHEN MTR-4 OPENS TO 30°, SW-10 WILL OPEN.
8. SW-21 SWITCH FORMS A BY-PASS CIRCUIT AROUND SW-10

MOVE SCREWDRIVER AT TOP ONLY TO ADJUST CAM

3/8" STRAIGHT BLADE SCREWDRIVER

RIGHT / INNER AUXILIARY SWITCH

SW-10 (IN MTR-4) (LOW FIRE START) BL/RED - BL/YL

SWITCH FOLLOWER

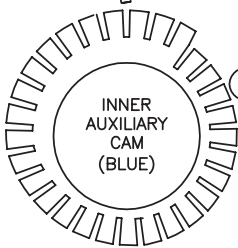

LEFT / OUTER AUXILIARY SWITCH

SWITCH FOLLOWER

SLOW RISE PORTION (APPROX. 10° DIFF.)

(APPROX. 1° DIFF.)

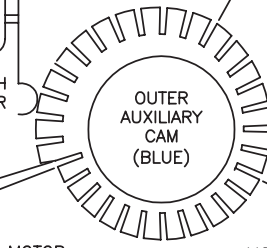

MOTOR OPEN - POWER END - MOTOR CLOSE

SW-11 (IN MTR-4) (BURNER CYCLING) RED - BLUE

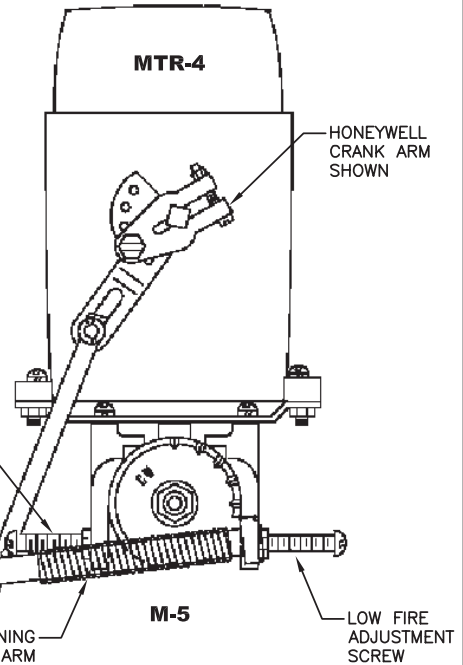

BUTTERFLY VALVE ASSEMBLY
MOTOR IN SHUT POSITION (TERMINALS R&W SHORTED) CLOCKWISE OPENING

C000714

SECTION V – UNIT START-UP WITH DDC CONTROLS

Before attempting to start the heater read and understand the sequence of operations, electrical schematic, flame safeguard control, control components, gas train, burner and the Digital Control System user manual.

WARNING: During installation, testing, servicing and trouble shooting of this product, it may be necessary to work with live electrical components. Have a qualified licensed electrician or other individual who has been properly trained in handling live electrical components to perform these tasks. Failure to follow all electrical safety precautions when exposed to live electrical components could result in death or serious injury.

Make sure all manual gas valves are closed.

Make sure all doors and service panels have been closed or replaced.

Turn main disconnect switch off. Check the incoming line voltage to match unit nameplate rating. If voltage is over +10% of nameplate rating or phase voltage unbalance is over 2%, notify contractor or power company.

Fans Are Enabled And Disabled By The Following:

MDT And MRT Standard:

By rotating the remote “Temperature Setpoint” knob (MP-15).

Clockwise will **enable** the fans.

Counterclockwise will **disable** the fans.

MRT-PRO With Smart Room Sensor:

To **enable** the fans and place the unit in the Occupied Mode, press the “Manual On” button on the face of the (TS-02) MRT-PRO room sensor. Pressing the “Warmer” button will add 30-minute increments of time for a total of 9-hours of operating time. To **disable** the fans and place unit in the Unoccupied Mode, press and hold down the “Manual On” button. Alternately pressing the “Manual On” button will also decrease the amount of operating time until it reaches zero and turns the fans off.

MRT Expert or MDT Expert With A BACview (KP-01):

To enable the fans, go to “Unit Modes” and enter [MANUAL], this mode will enable the fans.

To also **enable** the fans, go to “Unit Modes” and enter [AUTO]; this mode has four different functions that control the fans and unit operation. They are a Time Clock, Heating and Cooling Night Setbacks, and signal from an external source to an auxiliary digital input.

To disable the fans, go to “Unit Modes” and enter [OFF].

MRT-Touch or MDT-Touch with an Equipment Touch (KP-02):

To **enable** the fans, go to the Modes screen and change the Unit Mode to **Manual**. This mode will enable the fans.

To also **enable** the fans, go to the Modes screen and change the Unit Mode to **Auto**. This mode has five different functions that control the fans and unit operation. They are a Time Clock, Heating and Cooling Night Setbacks, a signal from an external source to an auxiliary digital input, and a network enable signal from a building automation system.

To **disable** the fans, go to the Modes screen and change the Unit Mode to **Off**.

NOTE: A BACview, Equipment Touch or PC is required to change Unit Modes. For a more detailed control sequence see the Digital Control User Manual.

If power supply meets requirements, turn main disconnect switch on and Enable fans. Damper opens (if applicable). After end switch has proven damper is open, the blower fan turns on. (See operating modes in Digital Control System user manual).

Disable the fans. Check supply blower for proper rotation. The burner and induced draft fan rotation will be checked when the heat section is started.

NOTE: To change rotation of the blower, simply interchange any two (2) of the line leads of the motor starter for three (3) phase motors. On single phase motors refer to motor nameplate.

Enable the fans. Check for proper blower rpm. Check that all motor amp draws do not exceed motor nameplate ratings and overloads are set to motor rating plate amps.

Check all dampers for proper operation, and linkage does not bind, see “Sequence of Operation”, and Digital Control System user manual for damper control modes.

Disable the fans.

NOTE: When setting up the burner for the first time of if appliance has been shut down for an extended period of time, these same start up procedures should be followed.

Open pilot and first main gas shut-off valves **slowly**.

Last main gas shut-off valve before burner must remain closed at this time. Reset high-low gas pressure switches (if applicable). Check pilot and main gas lines for leaks using soap solution.

Check the gas supply pressure by replacing the plug fitting on the pilot gas line with a pressure gauge with appropriate range. Check that pressure reading is within the specified range on the rating plate.

NOTE: To adjust gas pressure on supply lines where a regulator has been installed (to reduce the inlet pressure to rating plate maximum pressure), remove dust cap of main gas regulator and turn adjusting screw clockwise to increase pressure or counterclockwise to decrease pressure.

Heat is Enabled By The Following:

MDT And MRT Standard:

To **enable** the heat, rotate the “**Temperature Setpoint**” knob (**MP-15**) clockwise to the desired setpoint above the actual air temperature. The allowable temperature range is 55° to 90°F.

MRT-PRO With Smart Room Sensor:

To **enable** the heat, press the “**Warmer**” or “**Cooler**” button on the face of the remote **MRT-Pro** room sensor (**TS-02**) to the desired room setpoint. Each push of the button changes the temperature setpoint by 1°F. The setpoint can be changed a maximum of + 10°F from the default of 65°F. **Changing the heating setpoint also changes the cooling setpoint.**

MRT Expert or MDT Expert With a BACview (KP-01):

To enable the heat for MRT Expert scroll through the “**Setpoints**” menu in the BACview and enter the desired room Heating Occupied and Unoccupied Setpoints. For MDT Expert enter the desired Heating Discharge Air Setpoint.

MRT-Touch or MDT-Touch with an Equipment Touch (KP-02):

To **enable** the heat, go to the **Setpoints** screen in the Equipment Touch and enter the desired Heating Occupied and Night Setback setpoints.

Energy Savings Modes:

There are three (3) Energy Savings Modes that could disable the burner.

NOTE: A BACview or PC is required to change Setpoints. For a more detailed control sequence, see the Digital Control System Users Manual.

Sequence and Burner Setup with DDC

The I/O Zone 583 Controller (UC-01) must be calling for the burner to be enabled. The DO-2 light will be on and Burner Enable Relay (RE-28) needs to be energized. **If the outside or inlet air temperature is above the Heating Economizer Setpoint 65°F the burner will be disabled.** You will need to disconnect the plug where the Outside or Inlet Air Temperature Sensor (TS-01) and Discharge Air Temperature Sensor (TS-03) are wired to the I/O Zone 583 Controller (UC-01). Reconnect the plug if you are getting close to the Freezestat lockout time, which is approximately 3 minutes. To reset the Freezestat alarm, simply turn the power off and back on at the disconnect switch.

NOTE: A BACview, Equipment Touch or PC is required to change settings. See the Digital Control System User Manual for a more detailed sequence of operation.

Setting the Pilot Flame

CAUTION: Do not attempt to start the pilot when furnace is full of vapor or combustion chamber is very hot.

CAUTION: At no time should you stand in front of the relief door.

Honeywell Flame Safeguard Control (RE-02):

A keyboard display module (Honeywell #S7800A1142) is recommended to read the flame signal, and is a good troubleshooting device. A V.O.M. can also be used on the D.C. voltage test jacks marked “+” and “-“ on flame amplifier.

Connect manometer to pilot test tee (if applicable).

CAUTION: You will have approximately three (3) to nine (9) minutes (user-configurable by adjusting the Freezestat Buffer Time setpoint) before the unit shuts down on Freezestat (Low Discharge Temperature), if you have disconnected plug wires TS-01 and TS-03.

Enable the fan and heat as described earlier in this section. Check rotation of burner and induced draft fans, amps, and overload settings. Make sure the damper on the induced draft fan is approximately 75% open.

If limits and all safety controls are closed, the burner and induced draft fan will run for 90 seconds before ignition trial as a pre-purge cycle.

NOTE: Do not leave the Run/Test switch on the flame safeguard relay (RE-02) in the TEST position during P.F.E.P. for more than 60 seconds. This could cause the control program to go into a burner

status alarm. You can recycle the power to the unit to reset the burner status alarm.

NOTE: Pilot regulator adjustment may be needed if the adjustment of the needle valve does not yield the required reading. Typical adjustment of the needle valve is 1-1/2 to 2 turns open.

NOTE: Frequently the cause of pilot problems relates to gas pressures that are too high and/or air dampers that are closed too far. This causes a fuel rich mixture.

NOTE: 3 or 4 TRIALS MAY BE NEEDED TO PURGE AIR FROM PILOT LINE.

Watch D.C. voltmeter carefully. The reading should be steady and between 2.0 and 5.0 Volts D.C. If the reading is too low, slowly turn the needle valve in or out until satisfactory flame signal is obtained (see separate literature for testing of flame safeguard).

Make sure that the combustion air and pilot gas pressure is sufficient to provide instant ignition, a stable flame, and flame signal. Cycle pilot several times to insure reliability.

With pilot now adjusted, you can now shut down the burner by disabling the heat.

Setting the Main Flame

IMPORTANT: When the Flame Safeguard relay module is switched to the TEST mode, it stops and holds at the next Run/Test Switch point in the operating sequence. Make sure that the Run/Test Switch is in the RUN position before starting the burner.

CAUTION: Do not attempt to start the burner when furnace is full of vapor or combustion chamber is very hot.

CAUTION: At no time should you stand in front of the relief door.

Connect the test instruments, meters, and thermometers on the heater and controls to measure and record the appropriate data.

Install one manometer at test port on the last tee of the burner manifold and one at the relief door.

With all the safeties made, this will energize Burner Relay (RE-02) and burner will light. The I/O Zone 583 Controller (UC-01) will send a 0 to 10 VDC signal to the Interface Module (IM-02) located inside the Modulating Gas Valve Operator (MT-11). See check out procedure for (IM-02). At approximately 0 VDC the valve will be in low fire and 10 VDC is high fire. Prior to setting low and high fire you should have your test equipment installed and be familiar with the Butterfly Valve (GP-39) and its adjustment. For the high fire setpoint, refer to the unit rating plate for Normal

Manifold Pressure in inches of W.C. With the Modulating Gas Valve Operator (MT-11) in its high fire position set high fire using the Main Gas Pressure Regulator (GP-05) and with the high fire adjusting screw on the Butterfly Valve (GP-39). Remove the + or - wire from (IM-02) and set low fire with the low fire adjusting screw on (GP-39). See final checks and adjustments. Cycle the pilot and burner several times to be sure it lights off reliably.

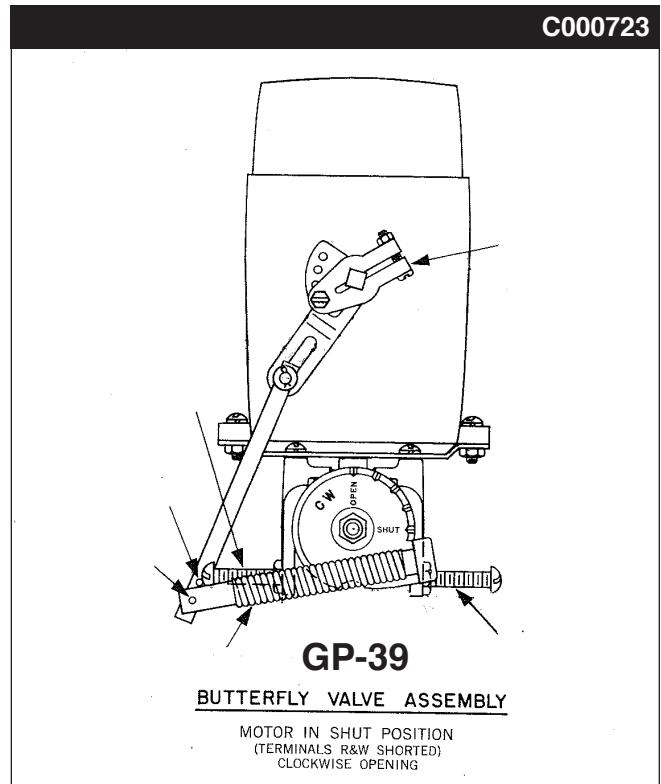

Enable the fans and heat as described earlier in this section.

Restart unit. After the pilot proves, the main automatic fuel valve(s) will be energized. **Slowly** open the last gas shut-off valve and the burner should light immediately.

CAUTION: If main flame does not light within a few seconds after pilot flame is established, shut the burner down and repeat steps. You may have to eliminate air from the main gas line. The main gas pressure and/or burner air setting may also need to be adjusted.

If flame signal drops significantly when main gas valves open, slightly increase or decrease pilot gas pressure to attain a steady flame signal.

After the burner lights; adjust gas pressure regulator, using a manometer, and combustion air damper to match the normal manifold pressure shown on unit nameplate. Make sure the setpoint and gas valves are in high fire.

These units have an induced draft fan, a minimum of -0.20" W.C. must be maintained at the relief door, simultaneously while setting the fuel to air pressure on the burner at full input. This is done by changing

the damper setting, at the induced draft fan outlet, with a warm stack. Be sure to lock down the locking quadrant when you are done.

Observe flame as burner modulates when setpoints are adjusted.

Note: Flame should modulate slowly and evenly throughout the entire travel, although flame may become somewhat “dirty” during travel. If stopped at any point, proper combustion should resume.

Observe low fire, it should be substantial enough to maintain proper combustion and be within the designed turndown range of the burner.

CAUTION: Too low of an input setting will cause condensation of the flue gases, this should be avoided unless condensate drains are provided.

Check all gas piping again for leaks using a soap bubble solution.

See final checks and adjustments.

FINAL CHECKS AND ADJUSTMENTS

After the burner has been in operation for at least 10 minutes, this allows the combustion chamber and heat exchanger to reach an equilibrium temperature; a flue gas analysis can now be performed. There is a test plug in the stand off box where the induced draft fan airflow switch tube is located.

The following readings should be taken but not limited to:

CO ₂ %	Net Stack Temperature
O ₂ %	Combustion Efficiency
CO %	

If necessary, make adjustments on burner air shutter. **DO NOT** change the fuel input rate.

The following list covers general combustion problems and some of the possible cures. Conditions may vary in the field. Refer to combustion chart for efficiency.

CAUTION: Check local codes for maximum allowable percentages and amounts of emissions.

Low Carbon Dioxide (CO₂)

- Fuel input too low
- Excess burner air
- Wrong draft setting

Detectable Carbon Monoxide (CO)

- Fuel input too high
- Not enough burner air
- Restricted draft
- Flame impingement

Excessive Stack Temperature (480°F Above Ambient)

- Draft setting too high
- Excess burner air
- Fuel input too high
- Blocked and/or restricted secondary tubes

Low Oxygen (O₂)

- Oxygen reading must always be a positive percentage

Make sure there is a minimum of -0.20" W.C. at relief door when burner is in high fire with a warm stack.

Cycle burner several times to ensure smooth light off and proper operation. Visually observe the flame pattern. There must be no flame impingement or hot spots on the combustion chamber that could cause scaling.

Check voltage and amperage on all motors.

Check all dampers, linkages, and locking quadrants to make sure they are secure and operating correctly.

Check all gas piping for leaks.

SAFETY AND CONTROLS CHECKOUT

Flame Safeguard – Close the last manual gas valve before burner. Operate unit in heat mode. After pilot flame has been established, quickly close manual pilot gas valve. The flame safeguard must trip out in approximately 15 seconds.

Gas Pressure Switches – The low gas pressure switch will trip out and must be reset before resuming operation when the inlet gas shut off valve is turned off, or inlet gas pressure is lower than the trip point. The high gas pressure switch can be checked by reducing the setting of its trip point lower than the burner operating pressure. The switch should trip out and shut off the burner. Return the adjustment to its original setting and reset to resume operation.

Temperature Controls – The temperature controls are checked by adjusting control to a higher temperature to allow burner to cycle on. Adjust control to a lower temperature to allow burner to cycle off. Return the adjustment to its original setting.

Air Pressure Switches – The air pressure switches can be checked by turning the adjusting screw to call for a higher pressure than is normally used on the system. Recycle is automatic when the switch returned to its original setting. If the burner or draft proving switches open, this could cause the flame safeguard to go into standby mode.

Limit Controls – The limit controls are checked by adjusting control to a lower temperature setting while the unit is operating on high fire and observe cut-off. Return the adjustment to its original setting. Manual reset may be required on some controls.

Make sure all the safeties and controls are working properly.

Cooling is Enabled By The Following

MDT & MRT Standard:

To enable the cooling, rotate the remote “**Temperature Setpoint**” knob (**MP-15**) clockwise to the desired setpoint below the actual air temperature. The allowable temperature range is 55° F to 90° F.

MRT-PRO With Smart Room Sensor:

To **enable** the cooling, press the “**Warmer**” or “**Cooler**” button on the face of the remote (**TS-02**) **MRT-Pro** room sensor to the desired room setpoint. Each push of the button changes the temperature by 1° F. The setpoint can be changed a maximum of +10° F from the default of 73° F. **Changing the cooling setpoint also changes the heating setpoint.**

MRT or MDT Expert With a (KP-01) BACview:

To **enable** the cooling for MRT Expert, scroll through the “**SETPOINTS**” menu in the BACview and enter the desired room **Cooling Occupied and Unoccupied Setpoints**. For MDT Expert, enter the desired **Cooling Discharge Air Setpoints**.

MRT-Touch or MDT-Touch with an Equipment Touch (KP-02):

To **enable** the cooling, go to the **Setpoints** screen in the Equipment Touch and enter the desired Cooling Occupied and Night Setback setpoints

Energy Savings Mode:

Energy Savings Mode 4-can disable the cooling.

NOTE: The cooling outputs are protected by an anti-cycle timer which has a 3 minute off / 3 minute on delay. A BACview, Equipment Touch or PC is required to change Setpoints. For a more detailed control sequence, see the Digital System User Manual.

SECTION VI - UNIT SHUTDOWN

A. Extended Shutdown

1. Disable the heat for 3 minutes, or a sufficient amount of time to allow the heat exchanger to cool down. Then disable the fans.
2. Close all the manual gas shut off valves.
3. Open the main electrical disconnect switch.
4. If the unit is to remain idle for an extended period, the fan and motor shafts should be rotated by hand to spread the grease over the bearings.

B. Emergency Shutdown Only —

1. Open the main electrical disconnect switch.
2. Close the main manual gas valve.

SECTION VII - TROUBLE SHOOTING

Check Safety Shutdown Performance

WARNING: Fire or explosion hazard. Can cause property damage, severe injury or death. Perform the safety shutdown test any time work is done on a gas system.

NOTE: Read steps 1 through 7 before starting, and compare to the safety shutdown or safety lockout tests recommended for the intermittent or interrupted pilot flame safeguard relay module. Where different, use the procedure recommended for the module.

1. Turn off gas supply.
2. Adjust setpoint above room temperature to call for heat.
3. Watch for ignition spark following prepurge. See flame safeguard relay module specifications.
4. Time the length of the spark operation. See the flame safeguard relay module specifications.
5. After the module locks out, open the manual gas cock and make sure no gas is flowing to the pilot or main burner.
6. Reset the flame safeguard relay (RE-02).
7. Operate system through one complete cycle to make sure all controls operate properly.

This equipment has been electrically and fire tested prior to shipment. However, during transit control setpoints can change, and wiring can come loose. Do not assume controls are defective until all associated setpoints and wiring are checked.

You also need to reference the Digital Control System User Manual for additional trouble shooting and diagnostics for units with DDC controls.

If you do not have the optional BACview 6 (KP-01) keypad display or Equipment Touch (KP-02) touchscreen display it will be difficult to troubleshoot any alarm that may occur on the unit. To reset most alarms on the I/O Zone 583 Controller (UC-01) without a BACview 6 keypad or Equipment Touch touchscreen, simply turn the power off and back on at the unit disconnect. If you have a BACview 6 keypad or Equipment Touch touchscreen the alarm can be reset remotely or at the I/O Zone 583 Controller.

The following is a simplified list of possible problems and typical causes and remedies. However, it does not cover all possibilities, and is intended as a guide only.

Refer to the burner manufacturer IOM for additional instructions.

WARNING: Many of the steps listed on the following pages require electrical cabinet and blower access while the unit is powered. High voltage and moving parts are present, and these steps should be performed by qualified service personnel. If any of the controls requiring manual reset were at fault this is an indication of a problem with the system that should be investigated.

SECTION VII - TROUBLE SHOOTING *continued*

HONEYWELL RM7897A1002, RM7897C1000 7800 SERIES RELAY MODULES

PRINCIPAL TECHNICAL FEATURES

The RM7897 provides all customary flame safeguard functions as well as significant advancements in safety, annunciation, and system diagnostics.

Safety Shutdown (Lockout) Occurs if:

1. INITIATE PERIOD
 - a. Purge card is not installed or removed.
 - b. Purge card is bad.
 - c. Configuration jumpers have been changed (after 200 hours) - Fault Code 110.
 - d. AC line power errors occurred, see Operation.
 - e. Four minute INITIATE period has been exceeded.
2. STANDBY PERIOD
 - a. Airflow lockout feature is enabled and the airflow switch does not close after ten seconds or within the specified purge card timing.
 - b. Flame signal is detected after 240 seconds.
 - c. Ignition/pilot valve terminal is energized.
 - d. Main valve terminal is energized.
 - e. Delayed main valve terminal is energized (RM7897C).
 - f. Internal system fault occurred.
 - g. Purge card is removed.
 - h. Purge card is bad.
 - i. Preignition Interlock open.
3. PREPURGE PERIOD
 - a. Airflow lockout feature is enabled and the airflow switch opens.
 - b. Ignition/pilot valve terminal is energized.
 - c. Main valve terminal is energized.
 - d. Delayed main valve terminal is energized (RM7897C).
 - e. Internal system fault occurred.
 - f. Purge card is removed.
 - g. Purge card is bad.
 - h. Flame signal is detected for 30 seconds.
 - i. Preignition interlocks open during stand by.
4. PILOT FLAME ESTABLISHING PERIOD (PFEP)
 - a. Airflow lockout feature is enabled and the airflow switch opens.
 - b. No flame signal at end of PFEP.
 - c. Ignition/pilot valve/intermittent pilot valve terminal is not energized.
 - d. Main valve terminal is energized (RM7897A).
 - e. Delayed (second stage) main valve terminal is energized (RM7897C).
 - f. Internal system fault occurred.
 - g. Purge card is removed.
 - h. Purge card is bad.
5. MAIN FLAME ESTABLISHING PERIOD (MFEP) (RM7897A, terminal 21)
 - a. Airflow lockout feature is enabled and the airflow switch opens.
 - b. Ignition terminal is energized.
 - c. Ignition/pilot valve terminal is not energized.
 - d. Main valve terminal is not energized.
 - e. Delayed main valve terminal is energized.
 - f. Loss of flame signal
 - g. Internal system fault occurred.
 - h. Purge card is removed.
 - i. Purge card is bad.
6. RUN PERIOD
 - a. No flame present (JR2 removed).
 - b. Airflow lockout feature is enabled and the airflow switch opens.
 - c. Interrupted pilot valve terminal is energized (RM7897A, terminal 21).
 - d. Main valve terminal is not energized.
 - e. Delayed main valve terminal is not energized (RM7897C).
 - f. Internal system fault occurred.
 - g. Purge card is removed.
 - h. Purge card is bad.
 - i. Ignition terminal is energized.

OPERATION

Sequence of Operation

The RM7897A has the operating sequences listed below; see Fig. 5 and 6. The RM7897A LED provide positive visual indication of the program sequence: POWER, PILOT, FLAME, MAIN and ALARM.

Initiate

The RM7897A Relay Module enters the INITIATE sequence when the relay module is powered. The RM7897A can also enter the INITIATE sequence if the relay module verifies voltage fluctuations of +10/-15% or frequency fluctuations of $\pm 10\%$ during any part of the operating sequence. The INITIATE sequence lasts for ten seconds unless the voltage or frequency tolerances are not met. When not met, a hold condition is initiated and displayed on the optional KDM for at least five seconds; when met, the INITIATE sequence restarts. If the condition is not corrected and the hold condition exists for four minutes, the RM7897A locks out.

SECTION VII - TROUBLE SHOOTING *continued*

Causes for hold conditions in the INITIATE sequence:

1. AC line dropout detection.
2. AC line noise that can prevent a sufficient reading of the line voltage inputs.
3. Low line voltage brownouts.

The INITIATE sequence also delays the burner motor starter from being energized and de-energized from an intermittent AC line input or control input.

Standby

The RM7897A is ready to start an operating sequence when the operating control input determines a call for heat is present. The burner switch, limits, operating limit control and all microcomputer-monitored circuits must be in the correct state for the relay module to continue into the PREPURGE sequence.

Normal Start-Up Prepurge

The RM7897A Relay Module provides PREPURGE timing selectable from two seconds to thirty minutes with power applied and the operating control indicating a call for heat.

1. The Airflow Interlock, burner switch, Run/Test switch and all microcomputer-monitored circuits must also be in the correct operating state.
2. The motor output, terminal 4, is powered to start the PREPURGE sequence.
3. The Airflow Interlock input closes ten seconds into PREPURGE or within the specified purge card timing; otherwise, a recycle to the beginning of PREPURGE or lockout occurs, depending on how the Airflow Switch selectable jumper (JR3) is configured.

Ignition Trials

1. Pilot Flame Establishing Period (PFEP):
 - a. When the PFEP begins:
 - (1) The pilot valve and ignition transformer, terminal 21 is energized. The RM7897A has an intermittent pilot valve, terminal 8 and interrupted pilot valve, terminal 21.
 - (2) Flame must be proven by the end of the ten second PFEP (four seconds if Configuration Jumper JR1 is clipped) to allow the sequence to continue. If a flame is not proven by the end of PFEP, a safety shutdown occurs.
 - (3) The pre-ignition interlock is ignored throughout the trial for ignition state.

2. Main Flame Establishing Period (MFEP):
 - a. After PFEP, and with the presence of flame, the main fuel valve, terminal 9, is powered. If a flame-out occurs, the relay module locks out or recycles (depending on status of jumper JR2) within 0.8 or 3 seconds, depending on the Flame Failure Response Time (FFRT) of the amplifier.
 - b. The RM7897A (terminal 21) has a ten second MFEP. After the Ignition Trials, the interrupted pilot valve, terminal 8 is de-energized. If a flameout occurs, the relay module locks out or recycles (depending on status of jumper JR2) within 0.8 or 3 seconds, depending on the amplifier FFRT.

Run

1. The RM7897C has a delayed main valve that is energized once the RUN period is entered.
2. The relay module is now in RUN and remains in RUN until the controller input, terminal 6, opens, indicating that the demand is satisfied or a limit has opened.

Post Purge

After demand is satisfied or a limit opens, de-energizing terminal 6, the Ignition/Pilot valve, main valve and delayed main valve, terminals 8, 9, and 21 are de-energized. The blower motor, terminal 4, remains powered during the specified programmed time. The Pre-Ignition Interlock closes within the first five seconds of Post Purge.

Run/Test Switch

The Run/Test Switch is located on the top side of the relay module, see Fig. 4. The Run/Test Switch allows the burner sequence to be altered as follows:

1. In the measured PREPURGE sequence, the Run/Test Switch, placed in the TEST position, causes the PREPURGE timing to stop.
2. In the Pilot Flame Establishing Period, the Run/Test Switch, placed in the TEST position, stops the timer during the first eight seconds of a ten-second PFEP selection or during the first three seconds of a four-second PFEP selection. It allows for pilot turn-down test and other burner adjustments. This activates a fifteen-second flameout timer that permits pilot flame adjustment without nuisance safety shutdowns. The Run/Test Switch is ignored during PFEP for the C relay module if terminals 8 and 9 or 9 and 21 are jumpered.

IMPORTANT: When the relay module is switched to the TEST mode, it stops and holds at the next Run/Test Switch point in the operating sequence. Make sure that the Run/Test Switch is in the RUN position before leaving the installation.

SECTION VII - TROUBLE SHOOTING *continued*

SETTINGS AND ADJUSTMENTS

Selectable Site-Configurable Jumpers

The relay module has three site-configurable jumper options, see Fig. 6 and Table 7. If necessary, clip the site-configurable jumpers with side cutters and remove the resistors from the relay module.

SERVICE NOTE: Clipping and removing a site-configurable jumper enhances the level of safety.

Figure 5 - Sequence Status LEDs

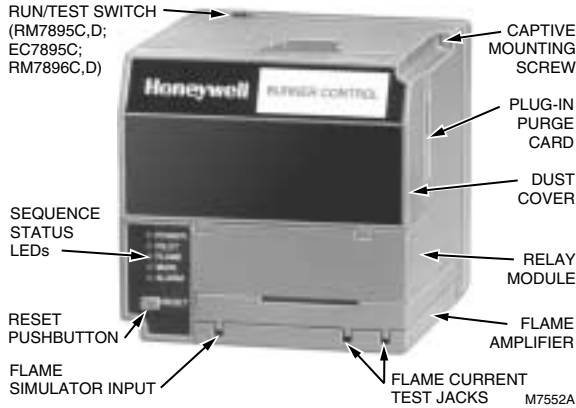

Figure 6 - Selectable Site-Configurable Jumpers

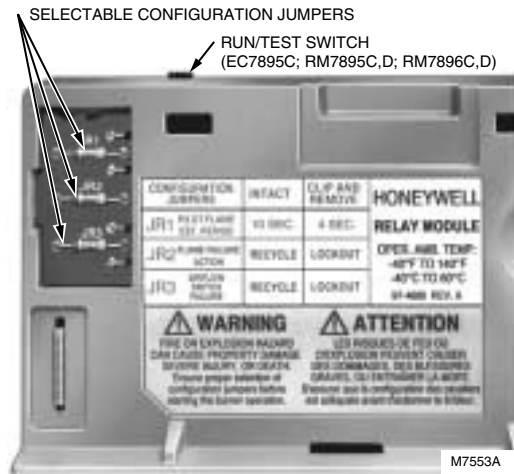

Table 7 - Site-Configurable Jumper Options

Jumper Number	Description	Intact	Clipped
JR1*	Pilot Flame Establishing Period (PFEP)	10 Seconds	4 Seconds
JR2	Flame Failure Action	Recycle	Lockout
JR3	Airflow Switch (ILK) Failure	Recycle	Lockout

IMPORTANT: Clipping and removing a jumper after 200 hours of operation causes a nonresettable Fault 110. The relay module must then be replaced.

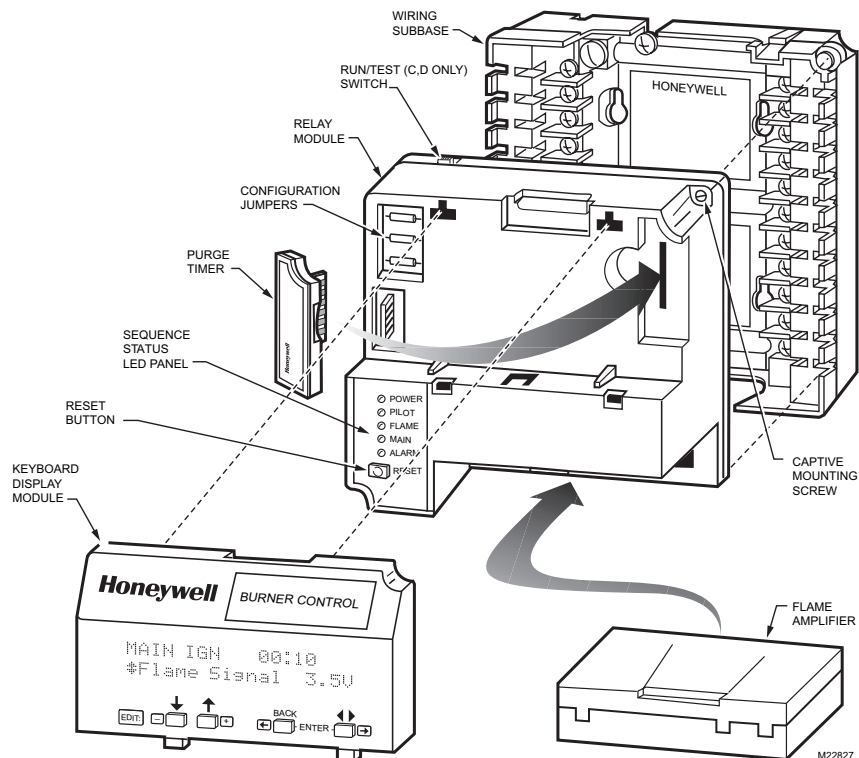
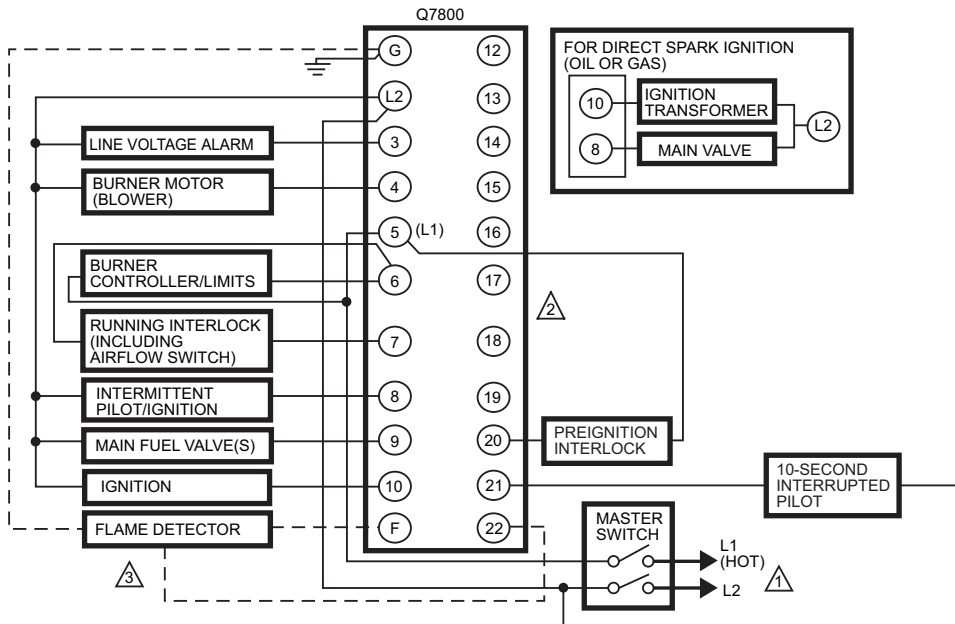

Figure 4 - RM7897A,C Relay Module Exploded View

SECTION VII - TROUBLE SHOOTING *continued*

Figure 2 - Wiring Subbase and Sequence Chart for RM7897A



	INITIATE (INITIAL POWERUP ONLY)	STANDBY	00 TIMED PREPURGE	00 PFEP 10 SEC. 4 SEC. IF JR1 CLIPPED	10 MFEP	20 RUN	00 POSTPURGE	STANDBY	
LED DISPLAY	● POWER	● POWER	● POWER	● POWER	● POWER	● POWER	● POWER	● POWER	
	○ PILOT	○ PILOT	○ PILOT	● PILOT	● PILOT	● PILOT	○ PILOT	○ PILOT	
	○ FLAME	○ FLAME	○ FLAME	● FLAME	● FLAME	● FLAME	○ FLAME	○ FLAME	
	○ MAIN	○ MAIN	○ MAIN	○ MAIN	● MAIN	● MAIN	○ MAIN	○ MAIN	
	○ ALARM	○ ALARM	○ ALARM	○ ALARM	○ ALARM	○ ALARM	○ ALARM	○ ALARM	
BURNER	BURNER/BLOWER MOTOR (5)								
			(10) IGN.						
			INTERMITTENT PILOT (8)						
			INTERRUPTED PILOT (21)						
			MAIN VALVE (9)						
OPERATING CONTROLS AND INTERLOCKS	LIMITS AND BURNER CONTROLLER CLOSED (L1) TO (6)								
	RUNNING INTERLOCKS CLOSED (6) TO (7)								
	PREIGNITION INTERLOCK CLOSED (5) TO (20)						PII		
FLAME SIGNAL	SAFE START CHECK				FLAME PROVING		SSC		

⚠ 1 120 VAC, 50/60 HZ POWER SUPPLY. PROVIDE DISCONNECT MEANS AND OVERLOAD PROTECTION AS REQUIRED.

⚠ 2 DO NOT CONNECT ANY WIRES TO UNUSED TERMINALS.

⚠ 3 SEE FLAME DETECTOR SPECIFICATIONS FOR CORRECT WIRING.

⚠ 4 PROGRAMMED ON SETUP USING S7800A1142 DISPLAY.

⚠ 5 PURGE TIME DEPENDS ON WHICH ST7800 IS INSTALLED.

M22728B

SECTION VII - TROUBLE SHOOTING *continued*

The POWER LED provides fault identification when the Relay Module locks out on an alarm. Fault identification is a series of fast- and slow-blinking LED lights. The fast blinks identify the tens portion of the fault code (three fast blinks is 30), while the slow blinks identify the units portion of the fault code (two slow blinks is 2). Three fast blinks followed by two slow blinks would be fault code 32. This identifies a running interlock on during STANDBY. (See following Table for Blinking Fault Code List.)

The LED code repeats as long as the fault exists. To clear the fault, press the RESET button.

Blinking Fault Codes and Recommended Troubleshooting

Fault Code	System Failure	Recommended Troubleshooting
Code 1-1 *Low AC Line Voltage*	Low AC Line detected.	<ol style="list-style-type: none"> 1. Check the relay module and display module connections. 2. Reset and sequence the Relay Module. 3. Check the 7800 power supply and make sure that frequency and voltage meet specifications. 4. Check the backup power supply, as appropriate.
Code 1-2 *AC Quality Problem*	Excessive noise or device running on slow, fast, or AC line dropout detected.	
Code 2-1 *Unexpected Flame Signal*	Flame sensed when no flame is expected during STANDBY or PURGE.	<ol style="list-style-type: none"> 1. Check that flame is not present in the combustion chamber; correct any errors. 2. Make sure that the flame amplifier and flame detector are compatible. 3. Check the wiring and correct any errors. 4. Remove the flame amplifier and inspect its connections. Reseat the amplifier. 5. Reset and sequence the relay module. 6. If the code reappears, replace the flame amplifier and/or the flame detector. 7. If the fault persists, replace the relay module.
Code 2-2 *Flame Signal Absent*	No-flame time present at the end of the Pilot Flame Establishing Period; lost during the Main Flame Establishing Period or during RUN.	<ol style="list-style-type: none"> 1. Measure the flame signal. If one exists, verify that it meets specifications. 2. Make sure that the flame amplifier and flame detector are compatible. 3. Inspect the main fuel valve(s) and valve connection(s). 4. Verify that the fuel pressure is sufficient to supply fuel to the combustion chamber. Inspect the connections to the fuel pressure switches. Make sure they are functioning properly. 5. Inspect the Airflow Switch and make sure that it is functioning properly. 6. Check the flame detector sighting position; reset and recycle. Measure the flame signal strength. Verify that it meets specifications. If not, refer to the flame detector and/or flame amplifier checkout procedures in the installation instructions. 7. Replace the flame amplifier and/or the flame detector, if necessary. 8. If the fault persists, replace the relay module.
Code 2-3 *Flame Signal Overrange*	Flame signal value is too high to be valid.	<ol style="list-style-type: none"> 1. Make sure the flame detector and flame amplifier are compatible. 2. Remove the flame amplifier and inspect its connections. Reset the flame amplifier. 3. Reset and sequence the relay module. 4. Check the flame detector sighting position; reset and recycle. Measure flame strength. Verify that it meets specifications. If not, refer to the flame detector and/or flame amplifier checkout procedures in the installation instructions. 5. If the code reappears, replace the flame amplifier and/or the flame detector. 6. If the fault persists, replace the relay module.
Code 3-1 *Running/ Interlock Switch Problem*	Running or Lockout Interlock fault during Prepurge.	<ol style="list-style-type: none"> 1. Check wiring; correct any errors. 2. Inspect the fan; make sure there is no air intake blockage and that it is supplying air. 3. Make sure the Lockout Interlock switches are functioning properly and the contacts are free from contaminants. 4. Reset and sequence the relay module to Prepurge (place the TEST/RUN Switch in the TEST position, if available). Measure the voltage between terminal 7 and G (ground); 120 Vac should be present. Switch TEST/RUN back to RUN. 5. If steps 1 through 4 are correct and the fault persists, replace the relay module.

Blinking Fault Codes and Recommended Troubleshooting

Fault Code	System Failure	Recommended Troubleshooting
Code 3-2 *Running/ Interlock On During Standby*	Lockout Interlock powered at improper point in sequence or On in Standby.	<ol style="list-style-type: none"> 1. Check wiring to make sure that the Lockout Interlocks are connected properly between terminals 6 and 7. Correct any errors. 2. Reset and sequence the relay module. 3. If the fault persists, measure the voltage between terminal 6 and G (ground), then between terminal 7 and G. If there is 120 Vac at terminal 6 when the controller is off, the controller switch may be bad or is jumpered. 4. If steps 1 through 3 are correct and there is 120 Vac at terminal 7 when the controller is closed and the fault persists, check for a welded or jumpered Running Interlock or Airflow Switch. Correct any errors. 5. If steps 1 through 4 are correct and the fault persists, replace the relay module.
Code 3-3 *VPS in Improper State*	VPS (Valve Proving Switch) in wrong state during VPS Test.	<ol style="list-style-type: none"> 1. Check wiring, making sure upstream valve is connected to terminal 9 and downstream valve is connected to terminal 17. 2. Conduct Valve Seat leakage test using a manometer. 3. Reset and sequence the relay module; if fault repeats, test VPS (connected to terminal 16) is functioning properly; replace if necessary. 4. Reset and sequence the relay module. 5. If fault persists, replace the relay module.
Code 4-1 *Purge Card Problem*	No purge card or the purge card timing has changed from the original configuration.	<ol style="list-style-type: none"> 1. Make sure the purge card is seated properly. 2. Inspect the purge card and the connector on the relay module for any damage or contaminants. 3. Reset and sequence the relay module. 4. If the fault code reappears, replace the purge card. 5. Reset and sequence the relay module. 6. If the fault code persists, replace the relay module.
Code 4-2 *Wiring Problem/ Internal Fault*	Pilot (ignition) valve terminal, main valve, ignition or Main Valve 2 was on when it should be off.	<p>⚠ WARNING Electrical Shock Hazard; Fire or Explosion Hazard. Can cause severe injury, death or property damage. Remove system power and turn off power supply.</p> <ol style="list-style-type: none"> 1. Remove system power and turn off fuel supply. 2. Check wiring; correct any errors. 3. inspect Pilot Fuel Valve(s), both places, and connections. 4. Reset and sequence the relay module. 5. If the fault persists, replace the relay module.
Code 4-3 *Flame Amplifier Problem*	Flame not sensed, or sensed when it should be on or off.	<ol style="list-style-type: none"> 1. Check wiring; correct any errors. 2. Make sure the flame amplifier and flame detector are compatible. 3. Remove the flame amplifier and inspect the connections. Reseat the amplifier. 4. Reset and sequence the relay module. 5. If the code reappears, replace the flame amplifier and/or the flame detector. 6. If the fault persists, replace the relay module.
Code 4-4 *Configuration Jumper Problem*	The configuration jumpers differ from the sample taken at startup.	<ol style="list-style-type: none"> 1. Inspect the jumper connections. Make sure the clipped jumpers were completely removed. 2. Reset and sequence the relay module. 3. If the fault persists, replace the relay module.
Code 5-1 *Preignition Interlock*	Preignition Interlock fault.	<ol style="list-style-type: none"> 1. Check wiring and correct any errors. 2. Check Preignition Interlock switches to assure proper functioning. 3. Check fuel valve operation. 4. Reset and sequence the relay module; monitor the Preignition Interlock status. 5. If the fault persists, replace the relay module.
Code 5-2 *High Fire Sw. or Low Fire Sw.*	Either High Fire Switch or Low Fire Switch failure.	<ol style="list-style-type: none"> 1. Check wiring and correct any errors. 2. Reset and sequence the relay module. 3. Use manual motor potentiometer to drive the motor open and closed. Verify at motor switch that the end switches are operating properly. Use RUN/TEST switch if manual potentiometer is not available. 4. Reset and sequence the relay module. 5. If the fault persists, replace the relay module.

Blinking Fault Codes and Recommended Troubleshooting

Fault Code	System Failure	Recommended Troubleshooting
Code 5-3 *Man-Open Sw.; Start Sw. or Control On*	Man-Open Switch, Start Switch or Control On in the wrong operational state.	<ol style="list-style-type: none"> 1. Check wiring and correct any errors. 2. Make sure that the Manual Open Valve Switch, Start Switch and Control are operating properly. 3. Stat Switch held iOni too long. 4. Reset and sequence the relay module. 5. Reset and sequence the relay module. If the fault persists, replace the relay module (RM7838A1014; RM7838B1013 or RM7838C1004 only).
Code 6-1 *Internal Faults*	Relay Module self-test failure.	<ol style="list-style-type: none"> 1. Reset and sequence the relay module. 2. If fault reappears, remove power from the device, reapply power, then reset and sequence the relay module. 3. If the fault persists, replace the relay module.
Code 6-2 *Internal Faults*	Relay Module Self-Test failure.	<ol style="list-style-type: none"> 1. Reset and sequence the relay module. 2. If fault reappears, remove power from the device, reapply power, then reset and sequence the relay module. 3. If fault does not repeat on the next cycle, check for electrical noise being copied into the relay module through the external loads or possibly an electrical grounding issue. 4. If the fault persists, replace the relay module.
Code 6-3 *Device Specific*	Fault with special OEM input circuits.	<ol style="list-style-type: none"> 1. Check wiring and operation of special OEM inputs. 2. Reset and sequence the relay module. 3. If fault reappears, remove power from the device, reapply power, then reset and sequence the relay module. 4. If the fault does not repeat on the next cycle, check for electrical noise being copied into the relay module through the external loads or possibly an electrical grounding issue. 5. If the fault persists, replace the relay module.
Code 6-4 *Accessory Fault*	Unused at this time.	—
Code 7-7 *Unused*	Unused at this time.	—

SECTION VII - TROUBLESHOOTING *continued*

Symptom	Cause	Remedy
<p>A. Supply fan(s) do not operate.</p>	<ol style="list-style-type: none"> 1. Low or no voltage. 2. Fuse(s) blown. 3. Customer's interlock not closed or connected. 4. Fan "on-off" switch in "off" position. 5. Door switch open. 6. Freeze protection tripped. 7. Damper motor not operating, its end switch not making, or dampers binding. 8. Overload protection on motor starter tripped. 9. Belts loose or broken. 10. Motor may be burned or incorrectly wired. 11. Time clock or field installed controls not closed. 12. Night set back thermostat not closed. 13. Bearing seized on shaft. 	<ol style="list-style-type: none"> 1. Check power source. 2. Replace fuse(s). 3. Close or connect customer interlock. 4. Switch to "on" position. 5. Close door, check and/or replace switch. 6. Check stat and settings, reset by re-cycling the power. Check sensor and location. 7. Check for power at damper motor and that end switch has been wired correctly. End switch should be wired N.O. (normally open). Clear linkage. 8. Reset the starter by pushing red button on starter, check amp draw. 9. Turn power off and check belts. 10. Turn power off and check motor and wiring. 11. Check time clock and field installed controls for correct settings and voltage. 12. Check night set back thermostat for correct settings. 13. Turn power off and check bearings.

SECTION VII - TROUBLESHOOTING *continued*

Symptom	Cause	Remedy
<p>B. No voltage at flame safeguard relay input terminals (RE-02).</p>	<ol style="list-style-type: none"> 1. Fan and Heat "off-on" switch in "off" position. 2. SW-11/SW-13 in MT-11/MTR-4 (if applicable) not closed. 3. Auxiliary switch on starter not closed. 4. Proof of closure switch open (if applicable). 5. Thermostat open. 6. High temperature limit is open. 7. High-Low gas pressure switches open. 8. Outside air temperature higher than on-off inlet ductstat setting. 9. Time clock or field installed controls open. 	<ol style="list-style-type: none"> 1. Place switch in "on" position. 2. Check modulating motor for proper operation (see sheet in manual). 3. Check auxiliary circuit wiring and contacts. 4. Check and see if gas valve is closed, check wiring on circuit. 5. Check thermostat for proper setting. 6. Check limit for proper settings. 7. Correct gas pressure and reset switches. 8. Check ductstat for proper setting. 9. Check time clock and field controls for correct settings and voltage.
<p>C. Flame safeguard relay (RE-02) goes into safety shutdown (Lockout).</p>	<ol style="list-style-type: none"> 1. See technical data sheets on flame safeguard relay. 	<ol style="list-style-type: none"> 1. Determine the cause of lockout. Push reset button on flame safeguard relay.
<p>D. Pilot does not light after 90 second pre-purge has timed out and voltage is present on flame safeguard output terminals.</p>	<ol style="list-style-type: none"> 1. Manual pilot shut-off valve closed. 2. Inlet gas pressure lower than minimum gas pressure required. 3. No gas through pilot regulator with sufficient inlet gas pressure. 4. No gas flow through pilot solenoid valve. 5. Type of gas supplied (natural gas or propane) different than shown on unit rating plate. 6. Flame detection system not sensing pilot flame. (See section for servicing burner). 7. No voltage on secondary side of ignition transformer. 	<ol style="list-style-type: none"> 1. <u>Slowly</u> open valve. 2. Increase gas pressure. 3. Clear obstruction in vent orifice or line, replace if defective. 4. Check for proper installation, and voltage. Correct or replace if defective. 5. Connect to proper fuel supply of contact factory for field conversion parts. 6a. U.V. Sensor – Clean lens, check wiring and spark rod. 6b. Flame Rod - Assure rod is in pilot flame, check wiring, and flame rod. 7. Check wiring. Replace transformer if defective.

SECTION VII - TROUBLESHOOTING *continued*

Symptom	Cause	Remedy
E. If pilot does not light after 90 second pre-purge has timed out and there is no voltage at flame safeguard relay output terminals.	<ol style="list-style-type: none"> 1. Flame safeguard relay run/test switch in test position or is defective. 2. Burner or draft motor not running 3. Burner or draft air proving switch is open. 	<ol style="list-style-type: none"> 1. Place switch in run position, see technical cut sheet on flame safe guard relay, or replace if defective. 2. Check wiring, fuses, and amp draw on motors. 3. Check for correct rotation of motors and/or adjust switch.
F. If there is no heat with pilot on and voltage is present at flame safeguard relay output terminals.	<ol style="list-style-type: none"> 1. Last manual gas shut-off valve closed. 2. No gas on outlet side of regulator with proper inlet pressure. 3. No gas on outlet side of valve or actuator with proper inlet pressure. 4. Low fire start switch, SW-10/SW-12 in MT-11/MTR-4 is open (if applicable). 5. Inlet gas pressure lower than the required gas pressure. 6. Normally open vent valve (if applicable) not closing. 7. Gas nozzles obstructed or plugged. 	<ol style="list-style-type: none"> 1. Turn Heat "off-on" switch to the "off" position. Slowly open all manual gas shut-off valves. 2. Clear obstruction in vent orifice or line. Check for correct size spring. Replace if defective. 3. Check wiring, voltage, and adjustment. Correct wiring or replace if defective. 4. Check for proper operation, see sheet in manual for proper settings. 5. Increase gas pressure. 6. Check for correct installation and voltage. Correct or replace. 7. Clear obstruction or blockage. (see burner IOM)
G. If there is no heat with pilot on and no voltage is present at flame safeguard relay output terminals.	<ol style="list-style-type: none"> 1. Flame safeguard relay run/test switch in test position or is defective. 	<ol style="list-style-type: none"> 1. Place switch in run position, see technical cut sheet on flame safeguard relay, or replace if defective.
H. Flame safeguard goes into alarm when main flame is trying to establish on units with interrupted pilot.	<ol style="list-style-type: none"> 1. Pilot gas pressure may be too high. 	<ol style="list-style-type: none"> 1. Adjust needle valve – typically 1-1/2 to 2 turns open from closed position.
I. Return air or outside air damper not functioning properly (see sequence of operations).	<ol style="list-style-type: none"> 1. Damper motor and/or end switch not wired correctly or defective. 2. Thermostat, relays and/or potentiometer not wired correctly or defective. 3. Dampers binding and/or loose. 	<ol style="list-style-type: none"> 1. Check wiring and/or replace end switch. 2. Check wiring and/or replace bad components. 3. Check and/or replace.
J. Cooling not functioning properly.	<ol style="list-style-type: none"> 1. Thermostat and/or relays not wired correctly or defective. 2. Setpoint is lower than design conditions. 3. Insufficient cooling. 4. Condensing section or evaporative cooler is not operating properly. 	<ol style="list-style-type: none"> 1. Check wiring and/or replace bad components. 2. Adjust thermostat to correct setpoint. 3. If desired space temperature is not reached and cooling is at full capacity, system may be undersized. 4. See Trouble Shooting Guide for your condensing section or evaporative cooler.

SECTION VII - TROUBLESHOOTING WITH DDC CONTROLS

Symptom	Cause	Remedy
<p>A. Supply fan(s) do not operate.</p>	<ol style="list-style-type: none"> 1. Low or no voltage. 2. Fuse(s) blown. 3. Customer's interlock not closed or connected. 4. Fan is disabled. 5. Door switch open. 6. DO-1 on UC-01 not energized. 7. RE-57 contacts not closed. 8. Freeze protection tripped. 9. Damper motor not operating, its end switch not making, or dampers binding. 10. Overload protection on motor starter tripped. 11. Belts loose or broken. 12. Motor may be burned or incorrectly wired. 13. Time clock or field installed controls not closed. 14. Auxiliary Unit Enable Switch (SW-09) not closed. 15. Bearing seized on shaft. 16. Multiplexed voltage values not correct. 	<ol style="list-style-type: none"> 1. Check power source. 2. Replace fuse(s). 3. Close or connect customer interlock. 4. Enable the fan(s). 5. Close door, check and/or replace switch. 6. See digital control system user manual. 7. Check power source and/or replace. 8. Check stat and settings, reset by re-cycling the power. Check sensor and location. 9. Check for power at damper motor and that end switch has been wired correctly. End switch should be wired N.O. (normally open). Clear linkage. 10. Reset the starter by pushing red button on starter, check amp draw. 11. Turn power off and check belts. 12. Turn power off and check motor and wiring. 13. Check time clock and field installed controls for correct settings and voltage. 14. Close switch (if applicable). 15. Turn power off and check bearings. 16. See multiplex voltage value chart.

SECTION VII - TROUBLESHOOTING WITH DDC CONTROLS *continued*

Symptom	Cause	Remedy
<p>B. No voltage at flame safeguard relay input terminals (RE-02).</p>	<ol style="list-style-type: none"> 1. Heat Mode is disabled. 2. Incorrect setpoint. 3. DO-2 or RE-28 is not energized. 4. Auxiliary switch on starter not closed. 5. Air flow switch open. 6. RE-27, RE-56 and/or RE-65 contacts open. 7. Proof of closure switch open (if applicable). 8. High temperature limit is open. 9. High-Low gas pressure switches open. 10. Outside air temperature higher than heating economizer setpoint. 	<ol style="list-style-type: none"> 1. Enable the heating mode. 2. Check for proper setting. 3. See digital control system user manual. 4. Check auxiliary circuit wiring and contacts. 5. Check for proper CFM. Adjust and/or replace switch. 6. See multiplexed voltage value chart. 7. Check and see if gas valve is closed, check wiring on circuit. 8. Check limit for proper settings. 9. Correct gas pressure and reset switches. 10. Check for proper setpoint.
<p>C. Flame safeguard relay (RE-02) goes into safety shutdown (Lockout).</p>	<ol style="list-style-type: none"> 1. See technical data sheets on flame safeguard relay. 	<ol style="list-style-type: none"> 1. Determine the cause of lockout. Push reset button on flame safeguard relay.
<p>D. Pilot does not light after 90 second pre-purge has timed out and voltage is present on flame safeguard output terminals.</p>	<ol style="list-style-type: none"> 1. Manual pilot shut-off valve closed. 2. Inlet gas pressure lower than minimum gas pressure required. 3. No gas through pilot regulator with sufficient inlet gas pressure. 4. No gas flow through pilot solenoid valve. 5. Type of gas supplied (natural gas or propane) different than shown on unit rating plate. 6. Flame detection system not sensing pilot flame. (See section for servicing burner). 7. No voltage on secondary side of ignition transformer. 	<ol style="list-style-type: none"> 1. <u>Slowly</u> open valve. 2. Increase gas pressure. 3. Clear obstruction in vent orifice or line, replace if defective. 4. Check for proper installation, and voltage. Correct or replace if defective. 5. Connect to proper fuel supply of contact factory for field conversion parts. 6a. U.V. Sensor – Clean lens, check wiring and spark rod. 6b. Flame Rod - Assure rod is in pilot flame, check wiring, and flame rod. 7. Check wiring. Replace transformer if defective.

SECTION VII - TROUBLESHOOTING WITH DDC CONTROLS *continued*

Symptom	Cause	Remedy
E. If pilot does not light after 90 second pre-purge has timed out and there is no voltage at flame safeguard relay output terminals.	<ol style="list-style-type: none"> 1. Flame safeguard relay run/test switch in test position or is defective. 2. Burner or draft motor not running 3. Burner or draft air proving switch is open. 	<ol style="list-style-type: none"> 1. Place switch in run position, see technical cut sheet on flame safeguard relay, or replace if defective. 2. Check wiring, fuses, and amp draw on motors. 3. Check for correct rotation of motors and/or adjust switch.
F. If there is no heat with pilot on and voltage is present at flame safeguard relay output terminals.	<ol style="list-style-type: none"> 1. Manual gas shut-off valve closed. 2. No gas on outlet side of regulator with proper inlet pressure. 3. No gas on outlet side of valve or actuator with proper inlet pressure. 4. Low fire start switch, SW-10/SW-12 in MT-11/MTR-4 is open. 5. Inlet gas pressure lower than the required gas pressure. 6. Normally open vent valve (if applicable) not closing. 7. Gas nozzles obstructed or plugged. 	<ol style="list-style-type: none"> 1. Disable the heat. Slowly open all manual gas shut-off valves. 2. Clear obstruction in vent orifice or line. Check for correct size spring. Replace if defective. 3. Check wiring, voltage, and adjustment. Correct wiring or replace if defective. 4. Check for proper operation, see sheet in manual for proper settings. 5. Increase gas pressure. 6. Check for correct installation and voltage. Correct or replace. 7. Clear obstruction or blockage. (see burner IOM)
G. If there is no heat with pilot on and novoltage is present at flame safeguard relay output terminals.	<ol style="list-style-type: none"> 1. Flame safeguard relay run/test switch in test position or is defective. 	<ol style="list-style-type: none"> 1. Place switch in run position, see technical cut sheet on flame safeguard relay, or replace if defective.
H. Burner will not respond to temperature.	<ol style="list-style-type: none"> 1. For units with DDC Controls. 	<ol style="list-style-type: none"> 1. See Digital Control System User Manual.
I. Flame safeguard goes into alarm when main flame is trying to establish on units with interrupted pilot.	<ol style="list-style-type: none"> 1. Pilot gas pressure may be too high. 	<ol style="list-style-type: none"> 1. Adjust needle valve – typically 1-1/2 to 2 turns open from closed position.
J. Return air or outside air damper not functioning properly (see sequence of operations for damper control).	<ol style="list-style-type: none"> 1. Building Pressure Transducer (PT-13), Damper Control Potentiometer (MP-05), or Photohelic Controller (PS-13) defective or not calibrated. 2. Building Pressure Transducer (PT-13), Damper Control Potentiometer (MP-05), or Photohelic Controller (PS-13) defective or not wired correctly. 3. Building Pressure Transducer (PT-13), Damper Control Potentiometer (MP-05), or Photohelic Controller (PS-13) defective or not installed correctly. 4. Unit Control Module (UC-01) defective. 5. Unit Control Module (UC-01) not wired correctly. 6. Two position switch defective. 7. Damper motor defective. 8. Dampers binding and/or loose. 	<ol style="list-style-type: none"> 1. Check and/or replace components. See section on trouble shooting PT-13. 2. Check wiring and/or replace bad components. 3. Install correctly. See section on trouble shooting PT-13 and manufacturer's cut sheet. 4. Check and/or replace. Contact Factory. 5. Check wiring. 6. Check and/or replace. 7. Check and/or replace. 8. Check and repair.

SECTION VII - TROUBLESHOOTING WITH DDC CONTROLS *continued*

Modulating Discharge Temperature (MDT, MDT-EXPERT, or MDT Touch) Controls

Symptom	Possible Cause	Field Test	Remedy
A. No Gas Flow with DO-2 or UC-01 energized.	1. Gas valves improperly installed.	1. Arrow on side or bottom of valves should point in direction of gas flow.	1. Install properly.
B. Continuous Low Fire (Electronics Problem).	1. Incorrect operation of Interface Module (IM-02). 2. No output voltage on UC-01.	1. Check for 2-10 VDC at IM-02 input terminals. 2. Check 0-10 VDC Voltage on AO-1.	1. See checkout procedure if voltage is correct. 2. Contact Factory.
C. Continuous Low Fire (Electronics OK).	1. Defective modulating gas valve operator (MT-11) and/or burned out transformer.	1. Inspect wiring (see checkout procedure in section X).	1. Replace modulating gas valve operator (MT-11) or transformer.
D. Incorrect Minimum Fire.	1. Incorrect low-fire butterfly valve (GP-39) adjustment.	1. See butterfly valve adjustment.	1. Adjust to proper minimum fire.
E. Continuous High Fire (Electronics Problem).	1. Open circuit in Outside or Inlet Air Temperature Sensor (TS-01) and/or Discharge Air Temperature Sensor (TS-03) circuit or wiring.	1. Check Outside or Inlet Air Temperature Sensor (TS-01) and/or Discharge Air Temperature Sensor (TS-03) for open internal circuit. See Thermistor curve.	1. Replace Outside or Inlet Air Temperature Sensor (TS-01) and/or Discharge Air Temperature Sensor (TS-03)
F. Continuous High Fire (Electronics OK).	1. Foreign object holding butterfly valve (GP-39) open.	1. Inspect linkage and valve.	1. Readjust linkage on valve or replace if necessary.
G. Incorrect High Fire.	1. Inlet pressure too low. 2. Incorrect outlet pressure adjustment of Pressure Regulator.	1. Read pressure at inlet to modulating valve using a manometer with unit operating at full fire. Pressure should be equal to the sum of outlet pressure setting plus pressure drop of the valve. 2. Read manifold pressure using manometer and compare with the pressure stated on the specification plate.	1. Increase inlet pressure if possible. 2. See Sequence and Burner setup in Section X.
H. Incorrect Discharge Air Temperature	1. Unit Enable Potentiometer (MP-15) not set correctly. 2. Discharge Air Temperature Sensor (TS-03) not reading correctly. 3. The Heating Discharge Air Setpoint on MDT-EXPERT Control System is not set correctly.	1. Check setpoint on Unit Enable Potentiometer (MP-15) 2. Check Discharge Air Temperature Sensor (TS-03) and wiring. See Thermistor curve. 3. Check setpoint with BACview, Equipment Touch, or PC.	1. Change to correct setpoint setting. 2. If readings are not correct, replace Discharge Air Temperature Sensor (TS-03) or repair wiring. 3. Change to correct setpoint. See Digital Control System User Manual.

(Refer to Digital Control System User Manual for additional troubleshooting suggestions)

SECTION VII - TROUBLESHOOTING WITH DDC CONTROLS *continued*

Modulating Room Temperature (MRT, MRT-PRO, MRT-EXPERT, or MRT-Touch) Controls

Symptom	Possible Cause	Field Test	Remedy
A. No Gas Flow with DO-2 on UC-01 energized.	1. Gas valves improperly installed.	1. Arrow on side or bottom of valves should point in direction of gas flow.	1. Install properly.
B. Continuous Low Fire (Electronics OK).	1. Defective modulating gas valve operator (MT-11) and/or burned out transformer.	1. Inspect wiring (see check out procedure in Section X).	1. Replace modulating gas valve operator (MT-11) or transformer.
C. Continuous Low Fire (Electronics Problem).	1. Incorrect operation of interface module (IM-02). 2. No output voltage on UC-01.	1. Check for 2-10 VDC at input terminals. 2. Check 0-10 VDC voltage on AO-1.	1. See checkout procedure if voltage is correct. 2. Consult factory.
D. Incorrect Minimum Fire.	1. Incorrect low fire butterfly valve (GP-39) adjustment.	1. See Butterfly Valve Adjustment.	1. Adjust to proper minimum fire.
E. Continuous Minimum Discharge Air Temperature.	1. Incorrect room temperature.	1a. Check Space Temperature Sensor (TS-02), use a BACview 6 or Equipment Touch to read TS-02 and Discharge Air Sensor (TS-03) for correct readings. See Thermistor curve. 1b. Check Space Temperature Sensor (TS-02) and/or Unit Enable Potentiometer (MP-15) setpoint. 1c. Check Heating Occupied and/or Unoccupied setpoint.	1a. Replace Sensors if reading is incorrect or correct wiring. 1b. Change to correct setpoint. 1c. Change to correct setpoint.
F. Incorrect Maximum or Minimum Discharge Air Temperature.	1. Maximum or minimum heating discharge temperature setpoint not set correctly.	1. Install a BACview 6, Equipment Touch, or PC.	1. Change to correct setpoints.

(Refer to Digital Control System User Manual for additional troubleshooting suggestions)

Control circuits external to MRT Controls can cause burner malfunction.

Always check manual valve to be certain gas is on, and check limit controls for normal operation.

SECTION VII - TROUBLESHOOTING WITH DDC CONTROLS *continued*

Modulating Room Temperature (MRT, MRT-PRO, MRT-EXPERT, or MRT-Touch) Controls *continued*

Symptom	Possible Cause	Field Test	Remedy
G. Continuous High Fire (Electronics OK).	1. Foreign object holding butterfly valve (GP-39) open.	1. Inspect linkage valve.	1. Readjust linkage on valve or replace if necessary.
H. Continuous High Fire (Electronics Problem).	1. Open circuit in Outside or Inlet Air Temperature Sensor (TS-01) and Discharge Air Temperature Sensor (TS-03)	1. Measure resistance per Thermistor Curve.	1. If readings are incorrect, replace Outside or Inlet Air Temperature Sensor (TS-01) or Discharge Air Temperature Sensor (TS-03) or repair wiring.
I. Incorrect High Fire.	1. Inlet pressure too low. 2. Incorrect outlet pressure adjustment.	1. Read inlet pressure at valve, using a manometer with heater operating at full fire. Pressure should be at least equal to the sum of: outlet pressure setting and pressure drop of the valve. 2. Read outlet pressure using manometer and compare with the pressure stated on the specification plate.	1. Increase inlet pressure if possible or change to larger valve. Consult factory about possibility of using special spring to reduce pressure drop on selected installations. 2. See Sequence and Burner Setup in Section X.
J. Continuous Maximum Discharge Air Temperature.	1. Open circuit in Discharge Air Temperature Sensor (TS-03). 2. Incorrect Maximum Heating Discharge Temperature Setpoint.	1. Measure resistance per Thermistor Curve. 2. Check to see if heater is delivering at Maximum Heating Discharge Setpoint.	1. If readings are incorrect, replace Discharge Air Temperature Sensor (TS-03) or repair wiring. 2. If desired temperature is not reached, increase Maximum Heating Discharge Temperature Setpoint.
K. Incorrect Space Temperature.	1. Incorrect Minimum Heating Discharge Temperature Setpoint. 2. Incorrect space setpoint. 3. Insufficient burner capacity.	1. Check to see if heater is delivering at Minimum Discharge Setpoint. 2a. Check Unit Enable Potentiometer (MP-15) Setpoint. 2b. Check Heating Occupied and/or Unoccupied setpoint. 3. Check to see if heater is operating at high fire.	1. If desired Space Temperature is not reached, increase Minimum Heating Discharge Setpoint. 2a. Change to correct setpoint. 2b. Change to correct setpoint. 3. If desired Space Temperature is not reached with heater at high fire, it may be undersized. Consult Factory.

(Refer to Digital Control System User Manual for additional troubleshooting suggestions)

Control circuits external to MRT Controls can cause burner malfunction.

Always check manual valve to be certain gas is on, and check limit controls for normal operation.

SECTION VII - TROUBLESHOOTING WITH DDC CONTROLS *continued*

Cooling Mode

Symptom	Cause	Remedy
A. There is no voltage at cooling relays (RE-34) (RE-35) and/or (RE-33) and the fan is enabled.	<ol style="list-style-type: none"> 1. Cooling mode is disabled 2. Auxiliary switch on starter (ST-01) is not closed. 3. Air flow switch open. 4. Cooling Changeover and/or Economizer Setpoints not set correctly. 5. DO-3 and/or DO-4 are not energized. 	<ol style="list-style-type: none"> 1. Enable the cooling mode. 2. Check auxiliary circuit wiring and contact. 3. Check for proper CFM. Adjust and/or replace switch. 4. Change to correct setpoints. See Digital Control User Manual. 5. See Digital Control System User Manual.
B. Cooling relays (RE-34) (RE-35) and/or (RE-33) are energized and condensing unit or evaporative cooler is not on.	<ol style="list-style-type: none"> 1. Cooling relays (RE-34) (RE-35) and/or (RE-33) contacts are not closed. 2. Cooling relays (RE-34) (RE-35) and/or (RE-33) contacts are not wired correctly. 3. Compressors or evaporative pump not running. 	<ol style="list-style-type: none"> 1. Check and/or replace. 2. Correct wiring. 3. See Troubleshooting Guide for your condensing unit or evaporative cooler.
C. Incorrect Space Temperature.	<ol style="list-style-type: none"> 1. Incorrect Maximum Cooling Discharge Temperature Setpoint. 2. Incorrect Minimum Cooling Discharge Temperature Setpoint. 3. Unit Enable Potentiometer (MP-15) not set correctly. 4. Cooling Occupied and/or Unoccupied setpoints not set correctly. 5. Insufficient cooling. 6. Condensing section or evaporative cooler is not operating correctly. 	<ol style="list-style-type: none"> 1. Decrease Maximum Cooling Discharge Temperature Setpoint. See Digital Control System User Manual. 2. Decrease Minimum Cooling Discharge Temperature Setpoint. See Digital Control System User Manual. 3. Change to correct setpoints. See Digital Control System User Manual. 4. Change to correct setpoint settings. See Digital Control System User Manual. 5. If desired Space Temperature is not reached and cooling is at full capacity, it may be undersized. 6. See Troubleshooting Guide for your condensing unit or evaporative cooler.

(Refer to Digital Control System User Manual for additional troubleshooting suggestions)

SECTION VII - TROUBLESHOOTING WITH DDC CONTROLS *continued*

To Calibrate the Building Pressure Transducer (PT-13)

1. Disconnect the tubes from the transducer.
2. **Make sure the Low and High fittings are clean and clear (do not insert any sharp objects into the pressure fittings). Make sure the tubing is also clean and clear of any debris.**
3. Connect the High and Low ports on the transducer together with a short length of tubing. Do not allow any kinks in the tubing.
4. Place the rotary switch into the [+/-] position. The current directional mode will show on the display. Press the NEXT button until -bl shows on the display.
5. Place the rotary switch in the [OUT] position. Press the NEXT button until 0 – 5 shows on the display.
6. Place the rotary switch into the [0] position. The display will show Aut0.
7. Press the NEXT button. The display will show a series of progress bars starting with one bar and ending with four. When the Auto Zero process is complete, the display will show “done” for approximately 4 seconds, then Aut0.
8. The voltage at Voltage Out and Gnd/4-20mA Out should now be 2.5 VDC.
9. Return the rotary switch to the [R1] position.
10. Reinstall the tubes on the transducer. **It is very important that the High tube be placed inside the building, and positioned so that air movement does not affect it. The Low side should be to atmosphere, and positioned so it is not exposed to the weather.**
11. With the use of a BACview 6 (KP-01) or Equipment Touch (KP-02) place the unit in the Building Pressure mode. (See the Digital Control System User Manual).
12. The voltage at Voltage Out and Gnd/4-20mA Out will vary between 0 to 5 VDC. 0 VDC means the building is in a negative pressure and should open the Outside Air Damper and close the Return Air Damper. 5 VDC means the building is in a positive pressure and should open the Return Air Damper and close the Outside Air Damper.

PT-13			
Bapi P/N	Mestex P/N	Range	Rotary Switch Position
ZPS-LR-EZ-NT-IN	68.0330.82	± 0.1 IN WC	R1



MULTIPLEXED VOLTAGE CHART

RESISTOR VALUE	RESISTOR ID	SWITCH CLOSED	OHMS IN CIRCUIT	VOLTS DC
1000	RS1	RS1,2,3,4	0	0
2000	RS2	RS2,3,4	1000	0.30
4020	RS3	RS1,3,4	2000	0.55
8060	RS4	RS3,4	3000	0.76
MULTIPLEXED VOLTAGE VALUES		RS1,2,4	4020	0.95
		RS2,4	5020	1.10
		RS1,4	6020	1.24
		RS4	7020	1.36
		RS1,2,3	8060	1.47
		RS2,3	9060	1.57
		RS1,3	10060	1.65
		RS3	11060	1.73
		RS1,2	12080	1.80
		RS2	13080	1.87
		RS1	14080	1.92
		NONE	15080	1.98
		UNPLUGGED	NA	3.30

IN-3	JUMPER	RS-04	MIXED AIR TEMP	= 1.36
TO	RE-56	RS-03	SAFETY CKT STATUS	= 1.73
GND	RE-09	RS-02	FLAME FAILURE	= 1.87
	SW-72	RS-01	100% OA or 100% OUTPUT	= 1.92
IN-4	RE-27	RS-04	BURNER STATUS	= 1.36
TO	RE-65	RS-03	FAN STATUS	= 1.73
GND	RE-12	RS-02	CLOGGED FILTER	= 1.87
	SW-09	RS-01	AUXILIARY UNIT ENABLE	= 1.92

CHECK ALL TERMINAL CONNECTIONS FOR TIGHTNESS

The DC voltage is to be checked at the UC-01 board

With the Fan Enabled:

When the fan status relay (RE-65) is energized, the contacts will close and the VDC at IN-4 & GND will be 1.73.

With the Fan and Burner Enabled:

When the safety circuit relay (RE-56) is energized, the contacts will close and the VDC at IN-3 & GND will be 1.73. When the burner status relay (RE-27) is energized, the contacts will close and the VDC at IN-4 & GND will be 0.76.

CHECKOUT PROCEDURE FOR INTERFACE MODULE (IM-02)

Q7230 Adjustments

The Q7230A provides adjustable range (zero and span) for two-wire current or voltage control. Separate potentiometers are provided on the circuit module for adjusting the zero point and the span. It includes a cw/ccw switch for configuring the motor to rotate clockwise or counterclockwise with an increase in control signal.

1. Set Mod IV motor pots – both CW or both CCW for your application. Use the checkout procedure in Table 3 to ensure proper motor function.
2. Verify that the zero potentiometer is fully clockwise and that the span potentiometer is fully counterclockwise. (Do not exceed the stop point of the potentiometer.)
3. Select desired rotation direction [cw (electrically normally closed) is the most common]. The following directions apply for the clockwise setting. For counterclockwise setting, reverse open and closed, and reverse clockwise and counterclockwise. Remove film on switch before use. (Default switch position is CW.)
4. For current control, connect the current input signal to I+ (screw terminal 3) and COM (screw terminal 5). For voltage control, connect the voltage input signal to V+ (screw terminal 1) and COM (screw terminal 5).
5. Set the controller to output the signal required to drive the motor to the closed position. Wait for the motor to stop driving closed.
6. Turn the zero potentiometer slowly counterclockwise until the motor starts to open.
7. Turn the zero potentiometer slowly clockwise until motor is fully closed. This is defined as the zero setting.
8. Set the controller to output the signal required to drive the motor to the fully open position. Wait for the motor to stop driving open.
9. Turn the span potentiometer slowly clockwise until motor starts to drive closed. The difference between the fully open position signal and the fully closed position signal is defined as the operating span.
10. Recheck the fully closed position and readjust the zero potentiometer, if necessary. (Turn the zero potentiometer clockwise to close the motor and counterclockwise to open the motor.)
11. Recheck the fully open position and readjust the span potentiometer, if necessary. (Turn the span potentiometer clockwise to close the motor, counterclockwise to open the motor.) Verify the mid point of your stroke.

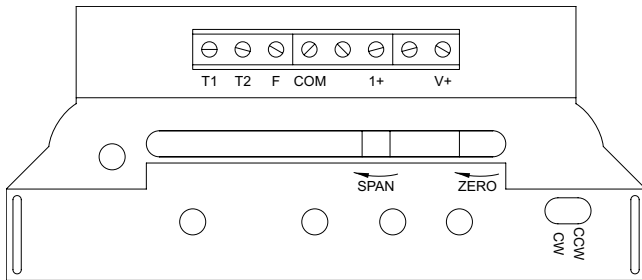

Fig 5. Q7230A terminals and adjustments.
C000719

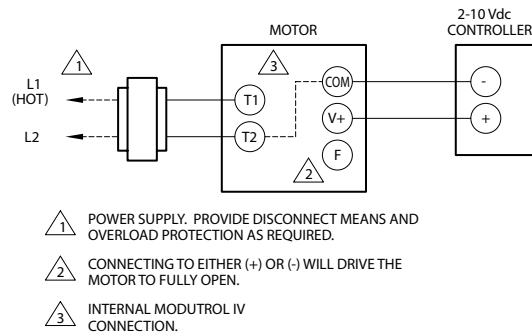

Fig 8. Typical wiring diagram for Q7230A Interface Module and M91XXX Modutrol IV Motor with 2-10 Vdc controller.
C000720

Table 3. Q7230/M91XX Checkout Procedure

Step	Proper Motor Response Switch in Clockwise Position	Switch in Counterclockwise Position
1. Open terminals (+), (-), F	Motor closes fully ccw	Motor closes fully cw
2. Jumper F to (-)	Motor opens fully cw	Motor closes fully ccw
3. Remove either T terminal	Spring return motors return to normal spring position (fully ccw for mechanically normally closed motors, fully cw for mechanically normally open motors).	

(+) and (-) denotes terminals on the controller

SECTION VIII - SERVICING THE BURNER

This section is intended as a guide in making some repairs and adjustments to the power burner. Many of the repairs will require the service of a skilled heating service technician. For more information refer to the burner I.O.M.

Power Flame Burners

1) GAS-ELECTRIC IGNITION

The gas-electric pilots used on Power Flame burners are either flame rod or scanner design.

2) POOR FLAME SIGNAL

Try adjusting needle valve or pilot pressure regulator. Should this not be successful, check the primary pilot air. If neither of these methods improve the reading, inspect the flame rod position.

The spark is to arc against the outside radius of the pilot assembly case (not the pilot head nozzle). The normal spark gap should be $1/16'' - 3/32''$. See the drawings for pilot assembly for the J-Burner.

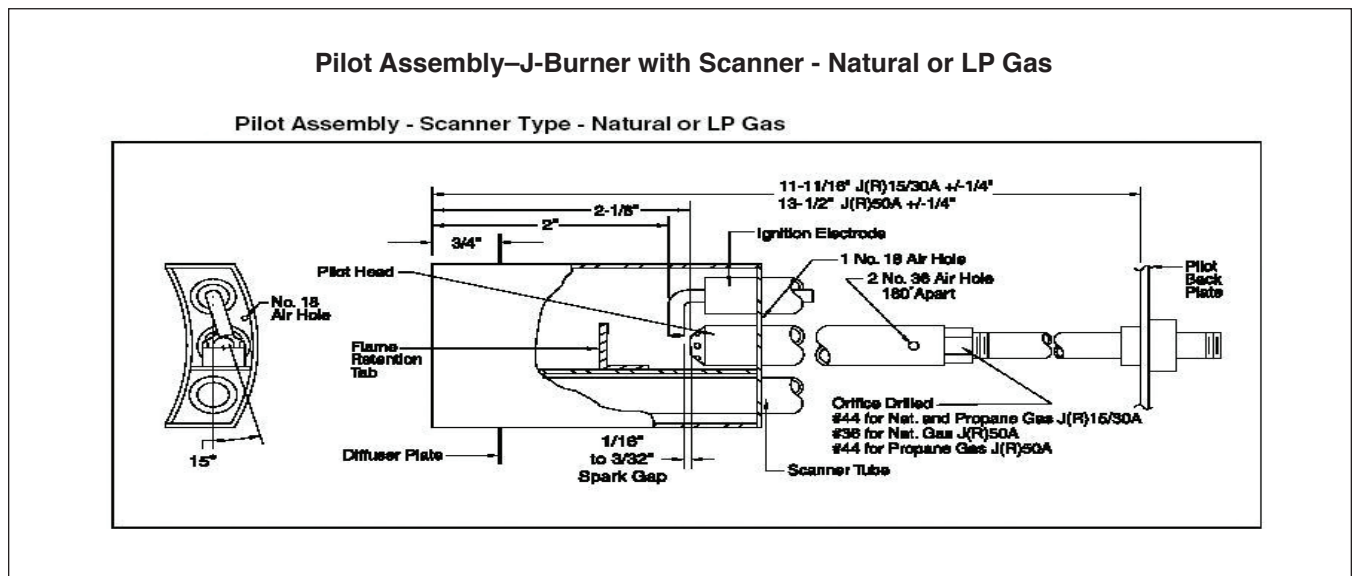
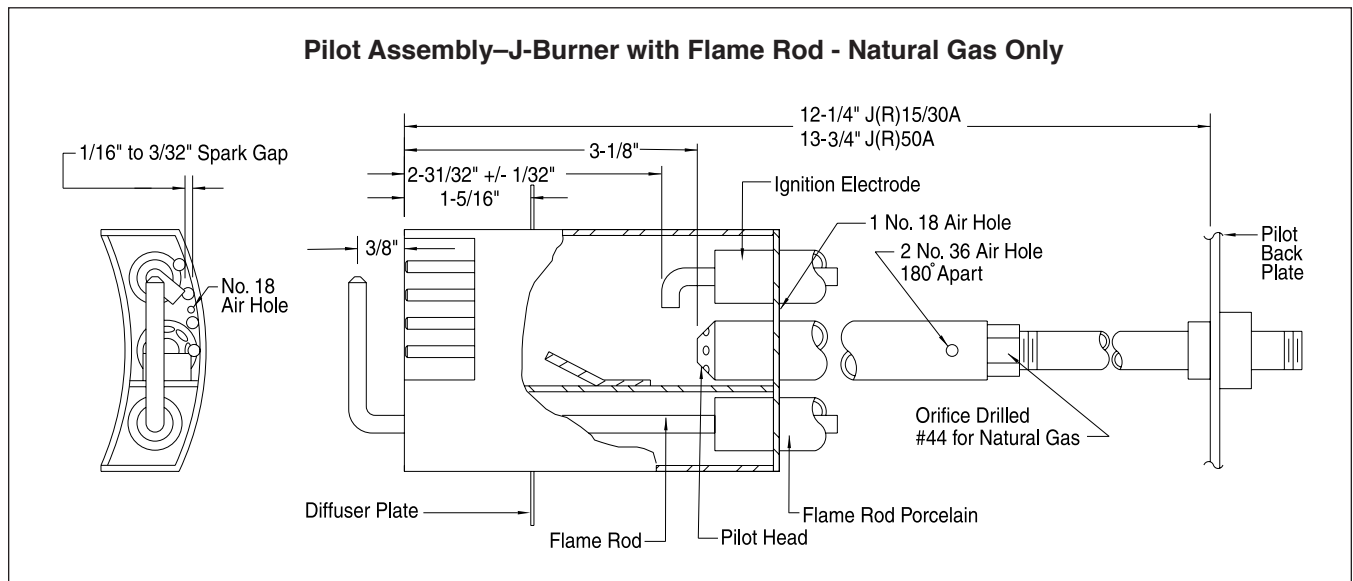

Pilot Positioning Safety Stop

Power Flame P/N X09668 retaining ring is assembled to the pilot assembly at the factory, and is not to be removed or repositioned at any time during the initial commissioning of the burner or during subsequent burner or pilot maintenance activities. Replacement pilots will also have this clip prepositioned and under no circumstances should it be moved from the factory set position, or tampered with in any manner.

This stop prevents the pilot from being retracted to a position which may cause pilot-to-main flame transition problems, while allowing sufficient room for minor pilot position adjustment.

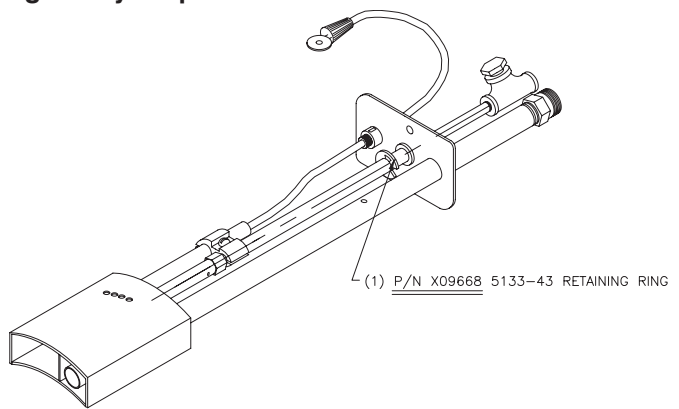

The arc from the electrode tip should jump from tip to the body of the pilot housing and should be lined with the hole in the backside of pilot housing, so that the blower air passing through this hole will cause the arc to "FLAG" (or move around). Normal spark gap should be $1/16'' - 3/32''$. The electrode should not be moved so far forward that the pilot flame will impinge on the porcelain insulator. This may cause damage to the porcelain. See the drawings for the pilot assembly for the C-Burner.

Pilot Assembly—C-Burner For C1 & C2 Burner

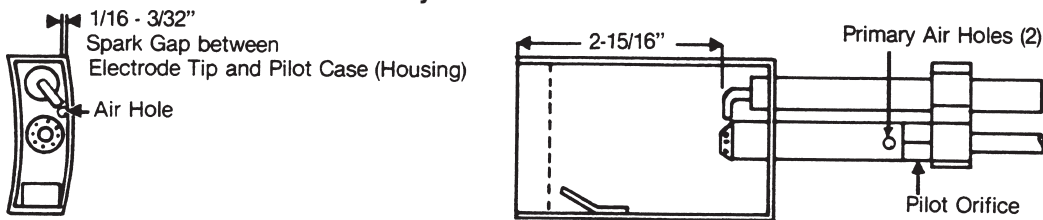

Pilot Assembly—C-Burner For C3, C4, & C5 Burner

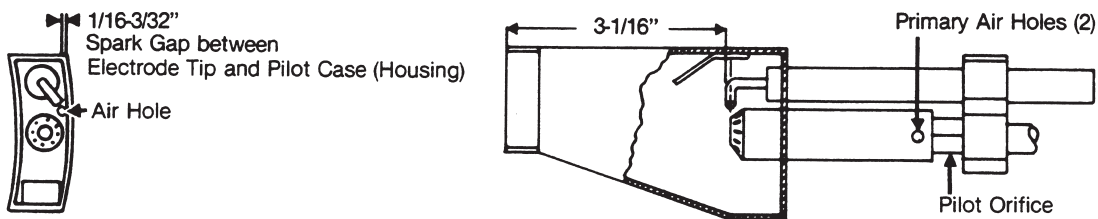

Pilot Case to Gas Manifold Adjustment

Pilot case to gas manifold adjustment is very important. As depicted, the inside radius of the pilot body must be tight against the outside radius of the gas manifold.

The bottom of the pilot body must also be tight against the notched portion of the baffle ring, just slightly above the scanner pipe. If there is an air gap between the pilot body and the gas manifold and/or the baffle ring, the resulting air flow may prevent the pilot flame from being swept downward across the scanner pipe.

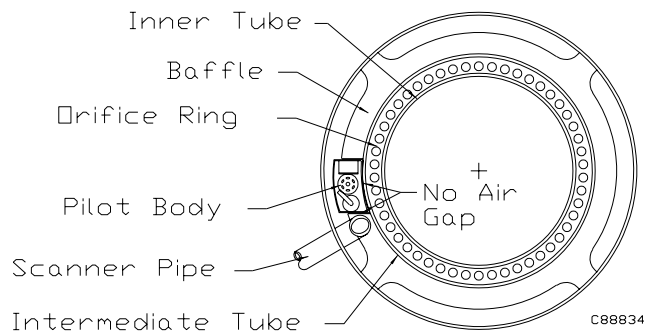

Gas, Oil or Gas/Oil Burner Diffuser Adjustment

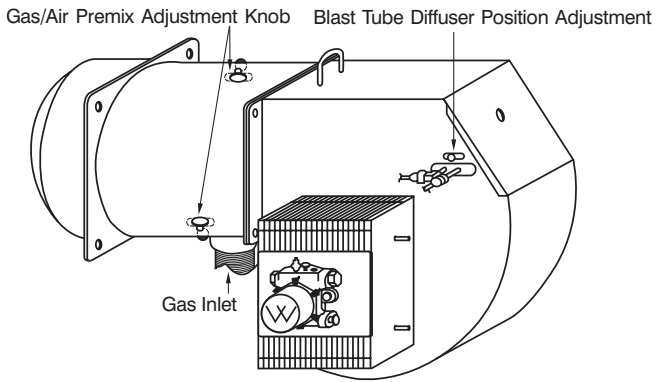

DIFFUSER POSITION ADJUSTMENT

Moving the blast tube diffuser assembly fore or aft on gas or oil firing will move the flame front (point of retention) in order to attain the best (quietest/smoothest) combustion for specific job conditions. If the initial mid-way point factory setting does not provide satisfactory results, move fore or aft in small increments to achieve the best combustion results. If unit is oil or combination gas/oil, the attached, flexible copper oil nozzle line will move fore or aft with the assembly. When firing on oil, moving the assembly forward will tend to broaden the flame pattern and moving it back will narrow the flame pattern. Similar results are obtained on gas, but observation of sound and combustion tests are the best determinants of results on either gas or oil.

G-P Burners

1) GAS-ELECTRIC IGNITION

The gas-electric pilots used on G-P burners are either flame rod or scanner design.

2) POOR FLAME SIGNAL

Try adjusting needle valve or pilot pressure regulator. Should this not be successful, check the primary pilot air. If neither of these methods improve the reading, inspect the flame rod position.

Ignition Electrode For Straight G-P Gas Burners Using A Flat Diffuser Plate

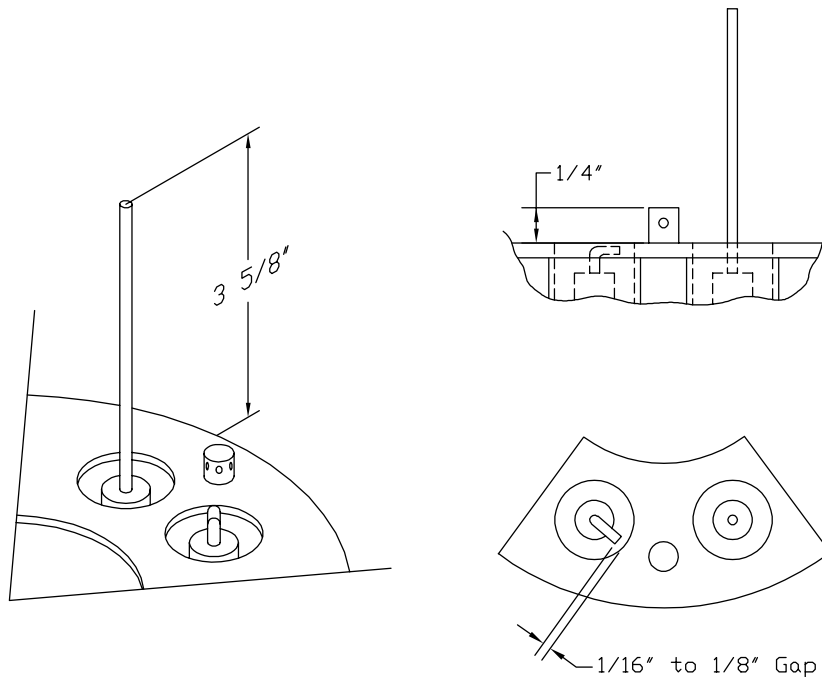

C000564

3) IGNITION ELECTRODE

The ignition electrode is positioned as shown, with the horizontal part of the electrode flush with the diffuser plate. Leaving a gap of $\frac{1}{16}$ inch to $\frac{1}{8}$ inch wide. The pointing direction of the electrode is as shown, but is not critical.

4) FLAME SENSOR

a. The flame sensor shown is a rectification, or a flame rod. A UV scanner can be used instead. In that case the scanner tube is positioned in the same holder as the flame rod.

MAXON MODEL (400) OVENPAK Burners

1) GAS-ELECTRIC IGNITION

The gas-electric pilots used on MAXON burners are either flame rod or scanner design.

2) POOR FLAME SIGNAL

Try adjusting needle valve or pilot pressure regulator. Should this not be successful, check the primary pilot air. If neither of these methods improve the reading, inspect the flame rod position.

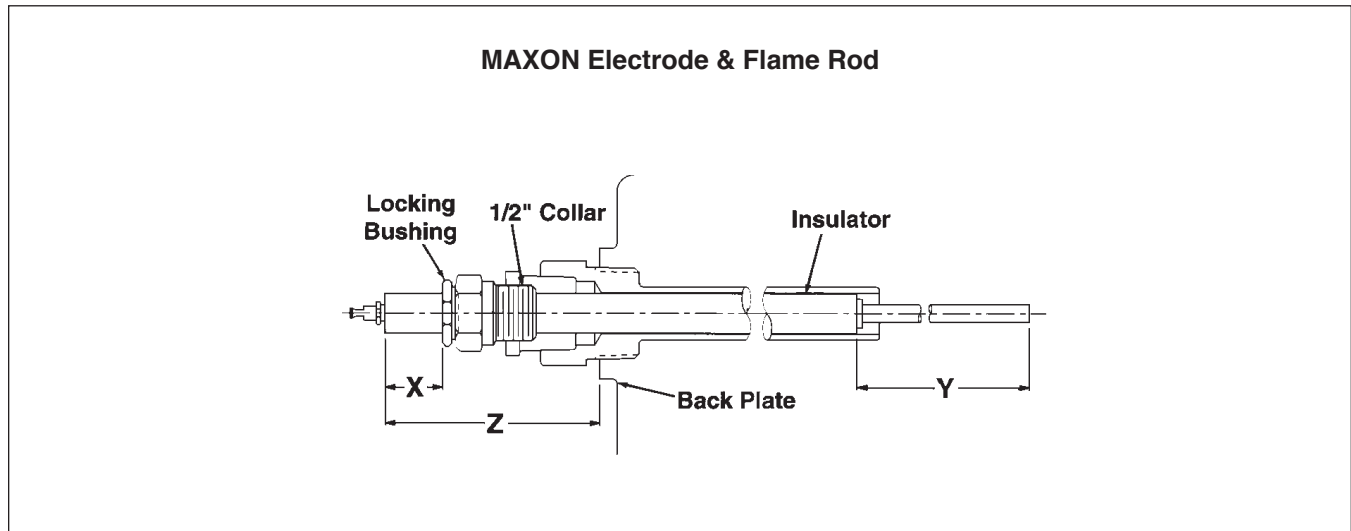

Burner Model	Spark Ignitor Dimensions		Flame Rod Dimensions		
	X	Y	X	Y	Z
405	1.3	.4	.4	6	2.9
407M					
408M					
408					
412M					
413M	1.5	.4			
415					
422M	1.2	.4	.8	10.8	3.5
425					
432M					
435					
442M	1.3	.4	.4	12.8	2.9
445					
456M					
470M					
487M					

FLUE GAS ANALYSIS

This curve correlates the relative values of O₂ and CO₂ for the fuels listed, as well as the percentage of excess air at given O₂ and CO₂ values.

Example: Following the dotted line on the vertical axis from 4% O₂ to curve H and the dotted line on the horizontal axis to the left, the % excess air column shows that 4% O₂ equals 25% excess air.

Following the vertical dotted line axis again from curve H to fuel A (Natural Gas) and the horizontal axis to the left, the % CO₂ column shows that 4% O₂ and 25% excess air correlate to 9-1/2% CO₂ for Natural Gas.

Again following the 4% O₂ vertical axis to fuel line E (#2 Fuel Oil) and to the left to the CO₂ column shows that 4% O₂ and 25% excess air correlate to 12-1/2 % CO₂ on #2 Fuel Oil.

This chart can be used to determine required CO₂ or O₂ values (and therefore equivalent BTU input values) for the secondary fuel when the burner has been properly adjusted for the primary fuel inputs.

Table 13

CO₂ - O₂ Ratio Curves for Fuel Oils and Gases

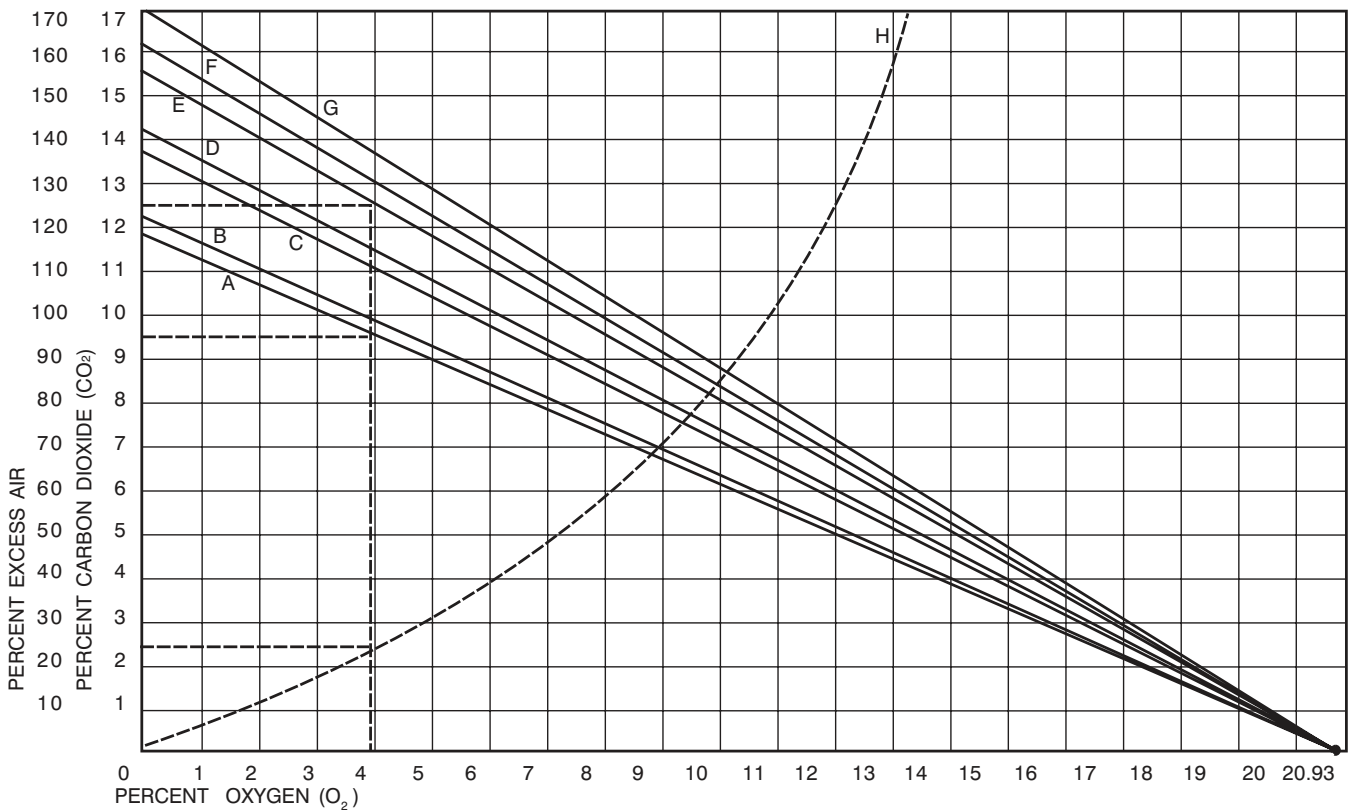

CURVE	FUEL	MAXIMUM CO ₂ %
A	Natural Gas	11.7
B	Natural Gas	12.1
C	Propane	12.1
D	Butane	14.0

CURVE	FUEL	MAXIMUM CO ₂ %
E	#2 Fuel Oil	15.2
F	#5 Fuel Oil	16.0
G	#6 Fuel Oil	16.9
H	Excess Air vs. O ₂	

SECTION IX - MAINTENANCE SCHEDULE AND LUBRICATION REQUIREMENTS

WARNING: Failure to comply with the general safety information may result in extensive property damage, severe personal injury or death.

Periodic maintenance is essential to the efficient operation and extended service life of this equipment. Failure to provide maintenance as recommended may void the equipment warranty.

A. Maintenance Schedule

1. Daily
 - a. Check gauges, monitors, instruments and equipment settings.
2. After 8 hours of operation
 - a. Check that fan belts are tight and sheaves are aligned. The fan belts can be checked every 30 days after the first 60 days of new belt run-in. **CAUTION:** Do not overtighten belts.
 - b. Check set screws and bolts on the fan, bearings, couplings, and burner assembly.
 - c. Check gas pressure at regulator.
3. After 48 hours of operation, check bearings for any unusual vibration or excessive temperature.
4. Monthly
 - a. Check all valves, piping and connections for leaks.
 - b. Check the pilot and burner flame signal, and safety lockout (RE-02).
 - c. Check the fuel pressure in the fuel supply line to each heater.
 - d. Check the burner manifold pressure and draft.
 - e. Do a flue gas analysis.
 - f. Inspect filters. Clean or replace as necessary.
 - g. Inspect main fan bearings; lubricate if necessary. See following section on bearing lubrication.
 - h. Check all dampers, damper actuators and linkages. Adjust and tighten if necessary.
 - i. Inspect area and make sure that no combustible or hazardous material has been stored within clearances as shown on the specification plate.
 - j. Check for any vibration or unusual noise. If any is observed, locate the cause and correct.
 - k. Ensure the supply, discharge, combustion air, vents, and stack remain clean and open.
 - l. Check and clear air sensing tubes and fittings. **CAUTION:** Remove tubes from switches and transducers before using compressed air to blow through tubing.
5. Quarterly
 - a. Complete the monthly maintenance schedule.
 - b. Inspect all drives for proper belt tension, wear, and alignment.
 - c. Check that bearings, fans, props, sheaves, and coupling setscrews are securely locked to the shaft.
 - d. Remove pilot assembly. Clean and adjust if necessary. (Refer to burner manufacturer IOM).
 - e. Check the voltage and amps on all motors.
 - f. Check the operation of all safety limits and controls. Clean and recalibrate or replace.
 - g. Check the operation of the automatic gas shut-off valves, and check them for leakage at the pressure test ports provided.
 - h. Inspect all electrical components, connections, and terminals. Clean or replace and tighten as necessary.
 - i. **For DDC Controls: Check that the battery in the UC-01 controller has 3 VDC. CAUTION: Do not remove the battery with the power to the unit turned off.**
6. Off Season or Yearly
 - a. Complete the monthly and quarterly maintenance schedules.
 - b. Inspect, and if necessary, clean all fan wheels, props, and housings.
 - c. Check all nuts and bolts for tightness.
 - d. Inspect all bearings and check condition and alignment.
 - e. Check the condensation lines for any leaks or blockages (if applicable).
 - f. Inspect all burner components.
 - g. Clean flame sensor, ignition electrodes, and check for cracks.
 - h. Test the flame safeguard relay (RE-02) and replace components if necessary.
 - i. Inspect all regulators, relief valves, motorized valves, solenoid valves, vent valves, manual shut-off valves, and safety shut-off valves. Check their operation and clean or replace as necessary.
 - j. Inspect and clean all drip legs in fuel lines and in the flue.
 - k. Remove the rear panel and the rear header box cover. Inspect the header box and tubes. Look for carbon deposits, soot, scale or rust. Clean if necessary.
 - l. Inspect the combustion chamber for carbon deposits, soot, scale, or signs of flame impingement. Clean if necessary. If there is evidence of flame impingement, a complete burner adjustment must be made.
 - m. Lubricate fan motors as directed by motor manufacturer. Inspect motors for loose connections.
 - n. Lightly oil all door latches.
 - o. Check that the cabinet is weather-tight. Replace door gaskets and re-caulk as needed.
 - p. Check the CO level in the entering and leaving airstream of the furnace. If the CO is greater in the leaving airstream, it is possible that the heat exchanger is leaking CO into the airstream. The leak must be located and repaired or replace the heat exchanger.

NOTE: Keep screened air intakes clear of obstructions at all times.

B. Lubrication Instructions

Item	Manufacturer	Bearing Type
All 3 phase fan motors (1 HP to 100 HP) ODP, TEFC <i>Recommendation: See following note.</i>	US., Baldor or equal	Single row ball bearings
All 1 phase motors (Fractional HP) ODP, TEFC or TEAO <i>Recommendation: See following note.</i>	Century, G.E., or equal	Bronze sleeve bearings
Fractional HP single phase, ODP or TEFC <i>Recommendation: See following note.</i>	Century, G.E. or equal	Bronze sleeve bearings
Fan shaft bearings <i>Recommendation: See following note.</i>	Fafnir or equal	Self-aligning single row or double row ball bearings, resilient mounted
Dampers <i>Recommendation: See following note.</i>	Factory or equal	Sleeve

1. Blower Motors – Some motors require lubrication while others do not. Those that require lubrication can be identified by the presence of grease plugs in the motor casing at each end. Motors that do not have grease plugs cannot be greased and are lubricated for the life of the motor bearing.

Lubrication of motors should be done while the motor is warm and at a standstill. Remove and clean all grease plugs and insert a grease fitting in the upper hole in the motor casing at each end. (Viewed as if motor were sitting horizontally on its base). There may be one or two plugs in each end casing of the motor. Add a small amount of a clean, good grade ball bearing grease, such as Exxon Polyrex EM or equal, with a low pressure grease gun. Run the motor five minutes before removing the grease fittings and replacing the plugs.

CAUTION: An excess of grease will overheat the bearings.

NOTE: On totally enclosed fan cooled (TEFC) motors, the rear end fan housing must be removed to expose the grease plugs.

2. Pillow Block Bearings – Pillow block bearings are used on supply blower(s). Bearings have been pre-lubricated with a number 2 lithium base grease. Relubrication should be done with a similar grease using a low pressure grease gun. Wipe all grease fittings clean before adding grease. Grease should be added slowly, in small amounts at frequent intervals while the shaft is being manually rotated.

A slight showing of grease at the seals with accompanying normal bearing temperature indicates proper lubrication. Normal temperature can range from “cool” to “hot to the touch” depending on size, speed and surrounding conditions. Excessive bearing temperature indicates faulty lubrication. An insufficient amount of grease is suggested by a bearing showing no grease at the seals, and a higher than normal temperature and noise level. Excessive leakage of grease at the seals, and a high operating temperature suggest too much grease.

Frequency of Lubrication – Frequency of lubrication depends upon operating conditions. The bearing operating temperature is the best index for determining a relubrication schedule. The following chart gives the frequency of relubrication based upon continuous operation for various operating temperatures and can be used as a satisfactory guide for determining when all ball and roller bearings should be relubricated.

Speed	Temperature	Cleanliness	Interval
100 RPM	Up to 125°F	Clean	6 months
500 RPM	Up to 150°F	Clean	2 months
1000 RPM	Up to 210°F	Clean	2 weeks
1500 RPM	Over 150°F	Clean	weekly
Any Speed	Up to 150°F	Dirty	1 week to 1 month
Any Speed	Over 150°F	Dirty	daily to 1 week
Any Speed	Any Temp.	Very Dirty	daily to 1 week
Any Speed	Any Temp.	Extreme Conditions	daily to 1 week

Browning Bearing Set Screw Torque Values

Model#	Shaft Size	Torque (in-lbs)
Set Screw		
VPS-212	3/4	66 - 85
VPS-214	7/8	66 - 85
VPS-116	1	66 - 85
VF2S-116	1	66 - 85
VPS-219	1 3/16	66 - 85
VF4S-219	1 3/16	66 - 85
VPS-220	1 1/4	126 - 164
VPS-223	1 7/16	126 - 164
VPS-323	1 7/16	126 - 164
VF4S-227	1 11/16	126 - 164
VPS-327	1 11/16	228 - 296
VPS-231	1 15/16	228 - 296
VF4S-231	1 15/16	228 - 296
VPS-331	1 15/16	228 - 296
VPS-235	2 3/16	228 - 296
VF4S-235	2 3/16	228 - 296
VPS-236	2 1/4	228 - 296
VPS-239	2 7/16	228 - 296
VF4S-243	2 11/16	348 - 452
VPS-343	2 11/16	348 - 452
VPS-347	2 15/16	348 - 452
BOA Concentric		
VPB-231	1 15/16	220 - 240
VPB-331	1 15/16	220 - 240
Spherical Roller		
SPB 1000 NE	1 3/16	290 - 380
SPB 1000 NE	1 7/16	290 - 380
SPB 1000 NE	1 11/16	290 - 380
SPB 1000 NE	1 15/16	290 - 380
SPB 1000 NE	2 3/16	290 - 380
SPB 1000 NE	2 7/16	620 - 930
SPB 1000 NE	2 11/16	620 - 930
SPB 1000 NE	2 15/16	620 - 930
Sealmaster SleeveLoc		
SPB 2115 C2	1 15/16	65

When replacing bearings refer to the manufacturers installation instructions included with the bearing.

Typical Procedure For Changing The Shaft And Bearings

1. Remove protective shaft coating.
2. Remove the drive side sheave.
3. Disconnect the grease lines from the existing bearings.
4. Identify the total shim thickness at each bearing and mark the bearing mount for future reference.
5. Remove mounting bolts for bearings and remove any shims.
6. Loosen bearing and blower wheel shaft setscrews.

7. Remove the shaft from the unit by sliding the bearings and blower wheels along the shaft as the shaft is extracted. Unless a blower wheel is damaged, it should be unnecessary to remove the blower wheel from the blower housing.
8. Slide the new shaft through the first blower wheel hub.
9. Once the shaft is completely through the first blower wheel, slide a bearing onto this end of the shaft.
10. Slide the shaft through the next blower wheel hub and add another bearing. Continue this procedure until the shaft is through all of the blower wheels.
11. Place a bearing on each end of the shaft.
12. Replace the old shims with new.
13. Bolt the bearings in place and reattach the grease lines. (When installing a SleeveLoc bearing see note at bottom of page).
14. Adjust the shaft so the blower hub keyways are in the middle of the shaft keyways.
15. Adjust the shaft so it protrudes past the non-drive end bearing, the blower sheave keyway mates with the shaft keyway, and the drive side sheave can be aligned with the motor sheave. Ideally, the blower sheave should be as close to the drive side bearing as possible, the motor sheave should be as close to the motor housing as possible, and the belts should be straight.
16. Be sure the shaft does not rub on or interfere with the closing of the access door.
17. Align all bearing setscrews, so that the same set screw on each bearing is pointed in the same direction as the other bearings' setscrews.
18. Place a drop of "BLUE" Loctite on the bearing setscrews and tighten all of the setscrews. Follow the mounting instruction's procedure on the inside of the bearing box, for the proper tightening and torque values.
19. Align the blower hubs' keyway with those in the shaft. Be sure the clearance between the blower wheel and blower housing is the same on each side.
20. Rotate the shaft by hand to insure free operation. Correct any rubbing of the blowers on the housings.
21. Place a drop of "BLUE" Loctite on the blower setscrews and tighten all of the setscrews.
22. Align the blower and motor sheaves using a laser or straight edge and tighten the blower sheave to the shaft.
23. Replace the belts and tighten the motor base adjustment for the proper belt tension. Over tightening the belt tension will severely reduce belt and bearing life. Belt deflection should be approximately 1/64 inch of the belt span.

24. Monitor for excessive heat or vibration during operation.
25. All bearings are pre-lubricated and should not require greasing. Refer to the bearing manufacturer's instructions or the unit manufacturer's instructions for proper bearing maintenance.

Note: Drive side SleeveLock bearing installation (USRB5000).

1. **Mount all the bearings and leave all the bolts and setscrews loose**
2. **Tighten setscrews on SleeveLock bearing to the tightening pattern as described in the installation sheet that comes with the bearing to a final 65 inch lbs while rotating the shaft. Check to make sure the insert of the bearing is centered in the bearing housing and then bolt bearing down.**
3. **Tighten down the bolts and setscrews on the remaining bearings per installation sheet starting from the end bearing back toward's the SleeveLock while rotating the shaft.**

3. Dampers – Dampers should be inspected monthly **(daily in icy weather)** for securely fastened linkages, and smooth operation. If dampers are binding or excessively noisy, then lubrication may be required. Place one drop of #20 wt. machine oil, silicone spray, graphite or equal on each blade bearing, and linkage ball joint. Do not over lubricate, and wipe any excess from the area. Be sure to note that dampers over 49 inches long have intermediate bearings which require lubrication.

3. Louvers – Louvers should be inspected monthly **(daily in icy weather)** to insure they are clean and clear.

C. Air Filters

All filter banks should be equipped with a manometer or differential pressure switch to indicate when the filters are dirty. Filters should be replaced when the differential pressure across them reaches the manufacturer's recommended final value. Dirty filter elements should be replaced with a clean element of the same type and size. In addition, the factory not only suggests, but insists, that air filters be **checked every 30 days (daily in icy weather)** and replaced with new filters (throw-away type) or cleaned (washable type) as required. Cleanable filters should be given new application of filter coating after washing to maintain optimum filter performance.

The frequency of cleaning and replacing air filters applies twelve months of the year, **where blowers are used for ventilation and heating.**

D. Belt Tensions and Adjustments

Belt tension is adjusted during the initial run-in and test periods at the factory. However, the belts are run as slack as possible to prevent excessive damage to the bearings, yet tight enough to prevent slippage.

It is necessary, therefore, to tighten all belts during the first few months of operation, and to **check for proper tension weekly during the first 60 days**, after which 30-day check intervals are sufficient.

WARNING: Turn off all power to the equipment before checking belt tensions.

CAUTION: Do not attempt to tighten any belt or belts by changing the pitch of an adjustable pulley, as this will change the speed of a driven pulley, causing the unit to be rendered OUT OF AIR BALANCE. Do not overtighten belts.

Suggested Belt Tension Method is with the use of a Belt Tension Checker

1. Check tension frequently during the first 24-48 hours of run-in operation. Ideal tension is the lowest tension at which the belt will not slip under peak load conditions. Over tensioning shortens belt and bearing life.

Alternate Belt Tension Method

2. To properly tension a conventional V-belt drive use the following procedure:
 - a. Measure the span length.
 - b. At the center of the span, apply a force perpendicular to the span to deflect the belt 1/64 inch for every inch of span length. For example, for a 40 inch span, apply a force that will deflect the belt 40/64 or 5/8 of an inch.
 - c. Compare the force you have applied with the values given in the table below. If the force is between the values for normal tension and 1-1/2 times normal tension, the belt tension should be satisfactory. If the belt tension is not within this range, it can be adjusted by loosening the motor mounting bolts, and adjusting the position of the motor along its base.

B Section

small pulley diameter range in Inches	Belt Manufacturer & Type Belt	Pounds Force for Normal Tension	Pounds Force for 1½ times Normal Tension
3.4-4.2	Gates Hi-Power	4.4	6.6
4.4-4.6	Gates Hi-Power	4.9	7.4
5.8-8.6	Gates Hi-Power	5.8	8.7

Note: For recommendation of other types of belts, consult respective manufacturers.

E. Optional Coils And Related Items

1. Coils – Coil surfaces must be kept clean of dirt and lint in order to operate at rated efficiency. Coils should be inspected on a regular basis and cleaned as required.

CAUTION: Solutions used to clean coils must not be corrosive to metals or materials used in the manufacture of this equipment. When using any type of coil cleaner, always read the manufacturer's warnings and directions to properly use their product. If cleaning solutions are applied through means of high pressure spray, care must be taken to avoid damaging coil fins.

2. Condensate Drain Pan – Periodically flush the condensate pan and drain system.

F. Gaskets

Gaskets are used on doors, inspection covers, some filter racks, and some outdoor air dampers. Inspect gaskets periodically and repair or replace as required.

G. Caulking

Inspect cabinet and add caulking as required.

H. Casing

Periodic cleaning of the casing is recommended to remove dirt, grease and any corrosive substances that may harm the finish. Rusted or corroded spots should be cleaned and repainted.

I. Support Means

Inspect the entire unit and burner support means to be sure everything is firmly in place.

J. Burner

Refer to burner manufacturer IOM for recommended burner maintenance.

**SECTION X - THERMISTOR OUTPUT CURVE
FOR UNITS WITH DDC CONTROLS**

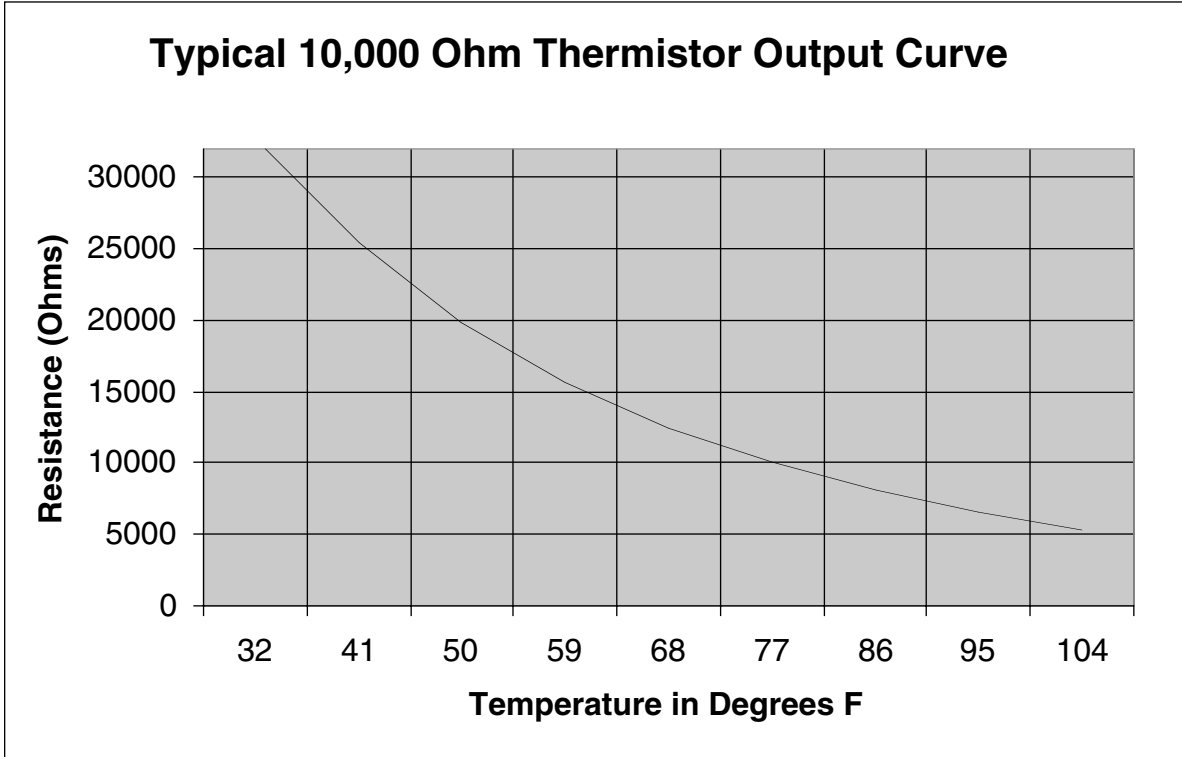

SECTION XI - REPLACEMENT PARTS

Replacement parts may be ordered from the factory. All warranty parts will be shipped freight allowed from the factory via standard ground service. Warranty parts must be returned within 30 days. Credit will be issued if part is complete, defective and returned on time.

NUMBER, FACTORY ORDER (F.O.) AND PART NUMBERS are required. Belts, filters and fuses are not covered under warranty.

Dealer/Contractor Name: _____

Address: _____

City: _____

State: _____ Zip: _____ Ph: _____

When parts are ordered, MODEL NUMBER, SERIAL



Applied Air®

4830 Transport Drive, Dallas, TX 75247
Phone: 214-638-6010
www.appliedair.com